

High Pressure Cold Water Jet Machine

Operating Manual

Model: SKY1020CET-SS

Series: Transformer

Pressure: 200 Bar

Flow: 10 Lpm



SKY TECH

AND CLEANING SYSTEMS PVT.LTD.

Touching New Horizon



+91 96192 68086

 sales@skyengg.in

www.skytechcleaning.com

 Unit No. 1, Behind Reliable Tech Park, Gavate Compound, Airoli (E), Navi Mumbai 400708

1. INTRODUCTION

The horizontal Plunger Pumps are designed and manufactured to pump or transfer **water**. They are generally driven by: electric motors, endothermic petrol or diesel engines and hydraulic motors, tractor P.T.O... Couplings may be fulfilled by means of transmission shaft, direct flanging, reduction unit or multiplier, joints, pulleys and belts.

The Pumps are supplied standard with the power take-off of the shaft on the right, looking at the Pump from the head (see fig.1). On request, all Pump models can be supplied with power take-off on the left.



The Pump is supplied to be installed on a more complex machine or plant; the manufacturer of such machine or plant shall add all the information related to safety of the assembled machine/plant fulfilled.

2. INTENDED USE

Plunger Pumps are designed to be used in machines or systems for transferring pressurized water, such as the following for example: Car Wash, Civil and Industrial Washing Systems, Road Washers and Bin Washers, Water Treatment, Misting, Drain and Pipe Cleaning and Fire-fighting.

The temperature of the workplace shall be between: Min. 0°C (32°F) - Max. 45°C (113°F)

The Pump cannot be used submerged under any type of liquid.

3. OPERATIONAL RESTRICTION

The specifications of the liquid to be used are described in detail herewith: do not use for different liquids; in particular, it is NOT possible to use Pumps in the following conditions:



- In the presence of water with high salt content, such as seawater for example; for this type of use, you are recommended to use Pump stainless steel series.
- In workplaces where there is a corrosive or explosive atmosphere.
- In the presence of any liquid that is not compatible with the constructional material of the Pump.
- To pump paint, solvents, fuel and any flammable liquid (not suitable for ATEX workplaces).
- To foodstuffs.
- To wash people, animals, live electrical or electronic equipment.
- To wash the Pump itself.

4. GENERAL WARNING



- Never start the Pump under pressure.
- Constantly check the state of wear of the pipes and relevant fittings, especially those under pressure. Pipes with signs of abrasion or that do not guarantee a perfect seal shall be replaced.
- The Pump must never run dry/without any liquid while in use.



- Protect rotating parts with a cover to prevent contact..
- The Pump is designed to be integrated in a machine or system, with various supply systems, which may make the noise level vary, even quite substantially. The manufacturer of such machine or system shall assess the level of noise emitted by the assembled machine or system and inform the user appropriately, also in relation to the use of suitable personal Protection equipment.

5. BEFORE START UP

LIQUIDS TO BE PUMPED

The Pump is designed and manufactured to transfer clean liquid or non-aggressive watery solutions.

The liquid in taken must be free from sand or other solid particles in suspension.

The liquid in taken shall have viscosity and density similar to water.

The maximum temperature of the liquid to be pumped varies according to the conditions of the system (see section 6.3 - INLET CONDITIONS).

Any other use is not admitted unless authorized in writing by the Engineering Department of **SKY**.

INLET AND OUTLET OF THE PUMP

The Inlet port for the liquid that must be pumped is generally located on the lower part of the Pump's

head and may also be called the suction port or supply port. The Outlet port for the pumped liquid is generally located on the upper part of the head and may also be called the delivery port. The Inlet and outlet ports may be used either on the right or the left side of the Pump's head, by dismantling or inverting the closure plugs.

 The Inlet and Outlet CANNOT be inverted.

INLET CONDITIONS (SUCTION)

Pump is mounted above the supply tank.	Pump is mounted below the supply tank in gravity feeding.	Pump is pressure fed.
Max. difference of level between Pump and supply tank: 0,5 m/1.6 ft.	Max. Pump speed: 1750 RPM.	Max. Inlet pressure: 6 bar (90 PSI).
Max. working pressure: 200 bar (3000 PSI).	Max. inlet water temperature up to 200 Bar (3000 PSI) of Working pressure: 50°C (122°F).	The feeding source must provide 50% more than the Pump flow.
Max inlet vacuum: -0.2 bar (-6 inch.Hg).		If a pressure feeding Pump is used, it must be started before the plunger Pump.
Max. Pump speed: 1450 RPM.	Max. Inlet water temperature over to 200 bar (3000 PSI) of working pressure: 35°C (95°F).	Max. Inlet water temperature: 50°C (122°F).
Max. Inlet water temperature: 40°C (104°F).		
<p>The inlet pipeline must comply with the following requirements:</p> <ul style="list-style-type: none"> - Any point of the inlet pipeline cannot be smaller than the diameter of the Pump inlet. - Be absolutely leak-proof to avoid any air infiltration - Not have 90° bends near the Pump inlet. - Not have contractions or restrictions. - Avoid any turbulence near the Pump inlet and in the supply tank. - If an inlet filter is used, it must allow 200% more flow than the flow required by the Pump. It must not cause any contraction or any pressure drop. The filter should be grant a filtration degree between 50 and 80 meshes and should be cleaned on a regular basis to ensure its proper functionality. 		

Any other use is not admitted unless authorized in writing by the Engineering Department of SKY.

OUTLET CONDITIONS

Make sure the delivery line and all the accessories are connected correctly, secured firmly, hermetically sealed and that the pipes are sized appropriately. All pressurized pipes must be marked durably with the maximum admitted pressure, which must never be less than the maximum working pressure of the Pump, written on the Label

SPEED AND ROTATION DIRECTION

 The rotation speed of the shaft of the Pump must never exceed the RPM written on the Label of the actual Pump.

The minimum RPM admitted is: maximum RPM x 0.6.
The rotation direction of the shaft of Pumps may be clockwise or anticlockwise.

6. CONTROLS ON SYSTEM

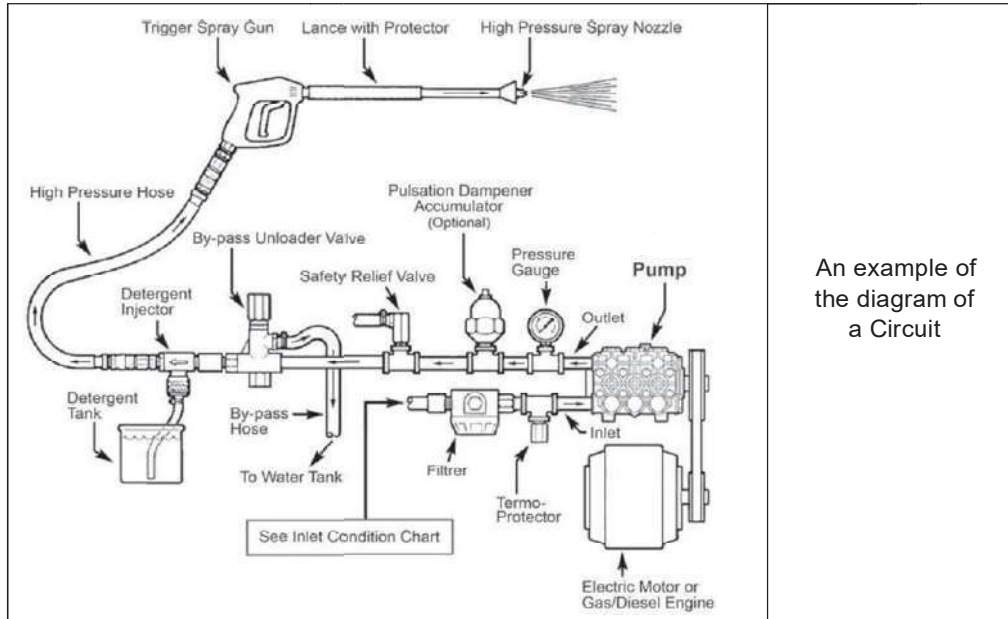

An example of the diagram of a Circuit

UNLOADER VALVE

A pressure regulator valve must be installed to avoid the pressure exceeding the maximum limit indicated on the Label of the Pump.

 Use of the Pump, even for a short period, with a pressure higher than such limit would damage the Pump itself.

The regulator valve shall be compatible with the maximum pressure, flow rate and temperature values written on the Label and in the "INLET CONDITIONS".

 Incorrect installation of the pressure regulator valve could cause serious personal injuries and damage to property as well as seriously damaging the actual Pump.

The circuit must be equipped with another safety valve to prevent the maximum pressure from being exceeded in the case of anomalies in the pressure regulator valve.

NOZZLE

A deteriorated nozzle could cause a drop in pressure; in this case, do not adjust the pressure regulator valve in the attempt to increase the pressure of the system because when the delivery line closes, this would cause a boost in pressure, which could damage the Pump.

If the pressure drops, it is advisable to replace the nozzle and adjust the system's pressure again. The flow rate of the Pump must be at least 10% higher than the flow rate that the utilities demand; the excess flow rate must be discharged.

PULSATION DAMPENER (ACCUMULATOR)

For applications in which pulses produced by the Pump on the delivery line are harmful or undesired, install an appropriately sized pulse dampener.

PRESSURE GAUGE

Install a gauge as near as possible to the outlet of the Pump because the maximum pressure written on the Pump's Label refers to the pressure detected on the head of the Pump and not on the nozzle or on other accessories.

 All the components of the machine or of the circuit must have technical specifications compatible

with the data written on the Pump's Label.

7. INSTALLATION, START UP AND SWITCHING OFF

POSITIONING

Smaller and lighter Pumps can be handled by hand in compliance with current standards. Heavier Pumps must be handled using the dedicated hook and suitable lifting device. If there is no eyelet and you need to use a lifting device, use appropriate strap/s, being careful not to damage the product. The weight of the Pumps is written in the table on page 25.

If the Pump is used in particularly dirty workplaces or is exposed to atmospheric agents, you are recommended to protect it, respecting the ventilation conditions.

ASSEMBLY

Fit the Pump on a rigid surface keeping the power take-off and support feet horizontal to ensure correct drainage in the case of leakage of water or oil. The Pump must be secured firmly on a base, which must be perfectly aligned with the transmission components. In the case of belt transmission, make sure the pulleys are aligned and check the tension of the belts.

Use appropriately sized hoses, both on the inlet and outlet of the Pump, according to the technical specifications written on the Label.

START UP

Before starting, check the following:



Replace the RED cap on the Pump Crankcase with the venting cap in the kit of accessories supplied.

- Check the oil level through the dedicated oil reservoir or inspection cap; top-up if necessary.
- Check the pressure value on the accumulator, if installed; inflate or deflate if necessary.
- The pressure regulator valve must be set at "0" pressure to favour intake.

Start and run the Pump for approximately 10 seconds until all the liquid has discharged from the delivery line. Once the intake cycle is complete, you can set the Pump at the required pressure, by adjusting the pressure regulator valve, without ever exceeding the maximum pressure written on the Pump's Label.

SWITCHING OFF AND STORAGE

After use or if the Pump is to be put away in storage, wash it internally. You can do this by running the Pump for several minutes with clean water, then disconnect the supply line and leave the Pump to run for approximately 15 seconds so that all the water in the head is discharged.

A few minutes devoted to the internal washing of the pump brings considerable benefits in terms of the pump's lifetime.



Do not wash the Pump externally: water could get into the Pump crankcase, for example through the oil vent cap.



After switching off, the Pump could remain very hot for some time.



Do not throw the liquid used to wash the Pump outdoors but observe current standards.

PRECAUTIONS AGAINST FREEZING

If shutdown during winter or in the case of places and seasons subject to frost, once the Pump has finished working, run it for the time required to pump an emulsion of 50% of clean water and 50% of antifreeze fluid through it in order to prevent freezing and damage to the Pump.

The Pump must not be used to Pump antifreeze fluid that is not mixed with water.

In the presence of ice or very cold temperatures at the workplace, the Pump must never be started; otherwise the Pump could be seriously damaged. To start the system, the whole circuit must be completely defrosted.

8. MAINTENANCE

ROUTINE MAINTENANCE

If the Pump is used for light-duty purposes, the following routine maintenance jobs are advised:

- After the first 50 hours: Oil change (see section 9.2 - Lubrication)
- Every 200 - 300 hours: Oil change (see section 9.2 - Lubrication)
- Every 1000 hours: Replace the valves - replace piston seal rings for heavy-duty purposes, carry out the maintenance jobs more often.



When inspecting or replacing the Pump valves, be careful which type of Loctite® you use on the caps over the valves (see table on page 26-27).

LUBRICATION

The Pump is supplied with the correct amount of lubrication oil (see table on page 25). Periodically check the oil level in the Pump through the oil level indicator.

Use **OIL type SAE 15W-40** or equivalent. Here are some recommended types of oil:

BRAND	TYPE
AGIP	F.1 Supermotoroil 20W-40
BP	Vanellus C 20W-40
CASTROL	GTX 20W-40
ESSO	Uniflo 20W-40
MOBIL	Super M 20W-40
SHELL	Rimula R4 20W-40 / Helix Super 20W40
TOTAL	Rubia 20W-40 / Quartz 5000 20W-40

The oil is to be changed by draining it through the dedicated bottom oil drain plug and strictly with the Pump stopped.

Every time you unscrew the oil drain plug we suggest replacing its gasket



DO NOT START THE PUMP IF THERE IS NO OIL IN THE PUMP!



During maintenance, you are recommended to:

- Use and wear suitable personal protection equipment (i.e. gloves). Wait for the machine to cool down and to have stopped completely.



During maintenance, do not throw residues outdoors but observe current standards.



If the Pump is to be scrapped:

1. Separate the various parts depending on their type (i.e. plastic, harmful fluids, metal etc.).
2. Use public or private waste disposal systems envisaged by local law to dispose of waste.
3. This device could contain harmful substances: improper use or incorrect disposal could have negative effects on human health and on the environment.

9. TROUBLE SHOOTING

PROBLEMS	PROBABLE CAUSES	SOLUTIONS
The Pump doesn't reach required pressure.	Incorrect or worn or plugged nozzle.	Change to proper size nozzle; replace nozzle or clean nozzle.
	Belt slippage.	Tighten or replace belt.
	Air leak in inlet plumbing.	Check or replace hoses or fittings.
	Inlet suction strainer clogged or improper size.	Check and clean, use adequate size.
	Worn seals. Abrasives in Pumped fluid; severe cavitations; inadequate water supply.	Install and maintain proper filter. Replace seals. Check inlet supply: Max. -0,2 bar (-6 inch.Hg) vacuum.
	Pressure gauge is broken or not registering accurately.	Check with new gauge; replace worn or damaged gauge.
	Relief / unloader valve stuck, partially plugged or improperly adjusted.	Adjust or repair or replace relief / unloader valve.
	Dirty or worn inlet or outlet valves.	Check and clean or replace valves.
	Leaky outlet hose.	Check or replace discharge hoses or fittings.
Pump is noisy.	Air leak in inlet plumbing.	Check or replace hoses or fittings.
	Inlet strainer clogged or improper size or insufficient supply of water to the Pump.	Check and clean, use adequate size; increase water supply if not sufficient.
	Dirty or worn inlet or outlet valves.	Check and clean or replace valves.
	Worn seals or o-rings.	Replace seals or o-rings.
	Plugged inlet filter or improper size.	Clean or replace filter.
	Pulley loose on crankshaft or worn key.	Check pulleys and key.
	Broken or worn bearings.	Replace bearings.
Water leakage under the Pump head.	Worn low pressure seal or o-ring.	Replace seal or o-ring.
	Cracked plunger.	Install new plunger.
Water in crankcase. Oil is changing color into white.	High humidity in air (condensing).	Change oil every 250 hours instead of 500.
	Worn crankcase oil seal.	Replace crankcase oil seal.
	Worn low pressure seal.	Replace seal.
Oil leak between crankcase and head.	Worn crankcase oil seal.	Check plunger rod. Replace crankcase oil seal.
Oil leak in the area of crankshaft.	Worn crankshaft oil seal.	Replace crankshaft oil seal.
	Worn bearing case o-ring.	Replace bearing case o-ring.
	Bad bearings.	Replace bearings.
Oil leak at the reared of the Pump.	Damaged or improperly installed sight glass or crankcase cover seal or drain plug.	Replace sight glass, plug or seals.
Frequent or premature failure of the packing.	Scored plungers.	Replace plungers.
	Over pressure in inlet manifold.	Reduce inlet pressure.
	Abrasive material in the fluid being Pumped.	Install proper filter on Pump inlet plumbing.
	Corrosive additives in the fluid being Pumped.	Use clean water or contact SKY Technical Service Department for more information's.
	Excessive temperature of fluid being Pumped.	Assure fluid inlet temperature are within specified range (see page 20).
	Running Pump dry.	Do not run Pump without fluid.
Excessive vibrations in outlet line.	Air leak in inlet plumbing.	Check or replace hoses or fittings.
	Pulsation damper pressure too low.	Check and repressure.
	Dirty or worn inlet or outlet valves.	Check and clean or replace valves.

PM

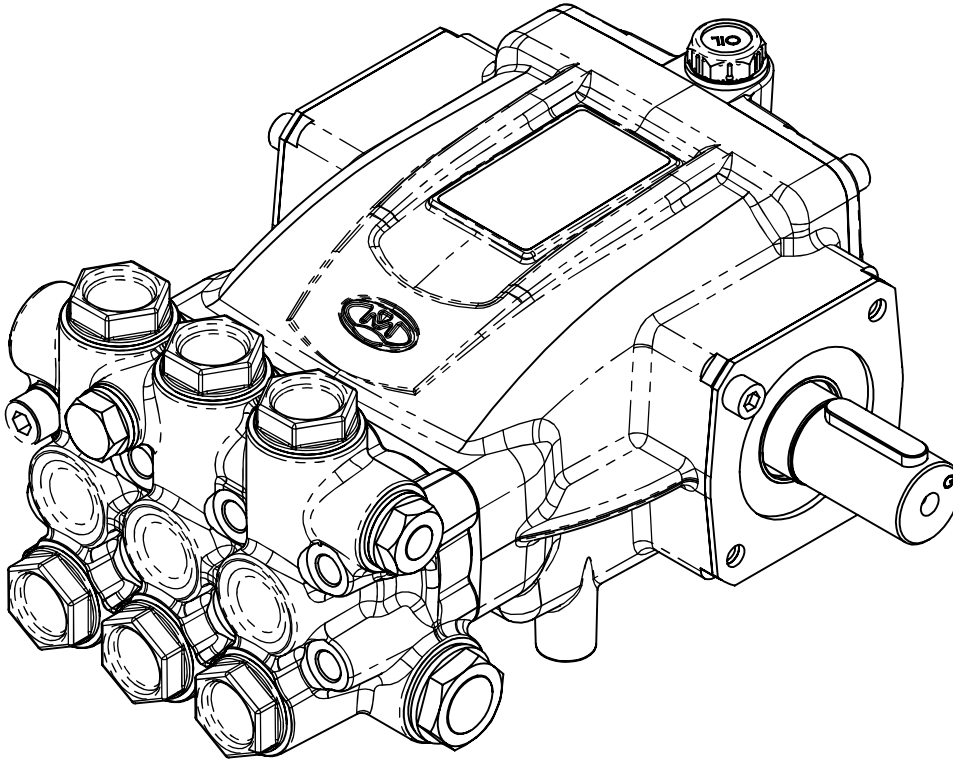

General table

Model	Pressure (Bar)	Pressure (Psi)	Flow Rate 1450 rpm (Lit/min)	Flow Rate 1740 rpm (Lit/min)	Flow Rate 1450 rpm (gpm)	Flow Rate 1740 rpm (gpm)	Round 50Hz (RPM)	Round 60Hz (RPM)	Power 50Hz (Hp)	Power 50Hz (Kw)	Power 60Hz (Hp)	Power 60Hz (Kw)
PM8170 (R-L)	170	2465	8.5	10.2	2.24	2.69	1450	1740	3.75	2.80	4.50	3.36
PM10170 (R-L)	170	2465	10	12	2.64	3.17	1450	1740	4.42	3.30	5.30	3.95
PM11170 (R-L)	170	2465	11	13.2	2.91	3.49	1450	1740	4.86	3.62	5.83	4.35
PM12170 (R-L)	170	2465	12	14.4	3.17	3.80	1450	1740	5.30	3.95	6.36	4.75
PM13170 (R-L)	170	2465	13	15.6	3.43	4.12	1450	1740	5.74	4.28	6.89	5.14
PM14170 (R-L)	170	2465	14	16.8	3.70	4.44	1450	1740	6.18	4.61	7.42	5.54
PM15170 (R-L)	170	2465	15	18	3.96	4.76	1450	1740	6.62	4.94	7.95	5.93

Exploded PM

Espoloso PM

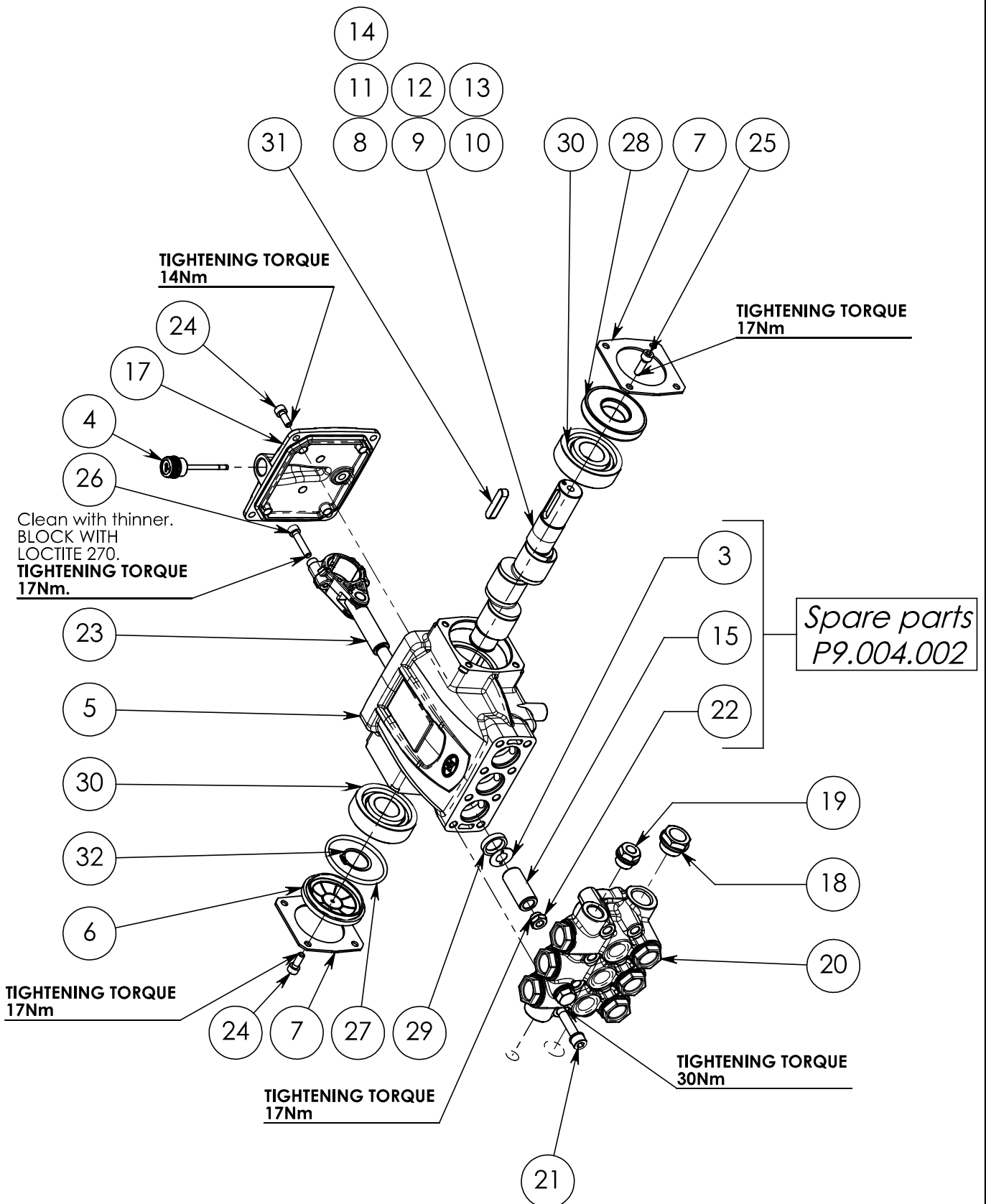



Pos.	PM 8170 (R-L) Q.TY		PM 10170 (R-L) Q.TY		PM 11170 (R-L) Q.TY		PM 12170 (R-L) Q.TY		PM 13170 (R-L) Q.TY		PM 14170 (R-L) Q.TY		Code	ITALIANO	ENGLISH	DEUTSCH	ESPAÑOL	FRANCAIS
	1	2	1	2	1	2	1	2	1	2	1	2						
2	1	1	1	1	1	1	1	1	1	1	1	1	P0.020.002	Olio o Lubrificante VANGUARD HYDRAULIC 0.5 LIT	Oil or Lubricants VANGUARD HYDRAULIC 0.5 LIT	Öl oder Schmierstoffe VANGUARD HYDRAULIC 0.5 LIT	Aceite o lubricante VANGUARD HYDRAULIC 0.5 LIT	Ölhuile ou lubrifiant VANGUARD HYDRAULIC 0.5 LIT
3	3	3	3	3	3	3	3	3	3	3	3	3	P1.003.001	Rondella Rame ø23.5xø11.2x0.5	Copper washer ø23.5xø11.2x0.5	Kupferunterlegsscheibe ø23.5xø11.2x0.5	Arandela de cobre ø23.5xø11.2x0.5	Rondelle cuivre ø23.5xø11.2x0.5
4	1	1	1	1	1	1	1	1	1	1	1	1	P1.012.009	tappo di livello con sfiato 3/8"Gas L.54	level cap with vent 3/8"Gas L.54	Level-Cap mit Lüftungs 3/8"Gas L.54	limite de nivel con el respiradero 3/8"Gas L.54	bouchon de niveau avec évent 3/8"Gas L.54
5	1	1	1	1	1	1	1	1	1	1	1	1	P1.020.002	Corpo PM	Body PM	Körper PM	Cuerpo PM	Corps PM
6	1	1	1	1	1	1	1	1	1	1	1	1	P1.054.003	Coperchio Spia ø61.8	Spy cover ø61.8	Abdeckung Spion ø61.8	Cubierta espía ø61.8	Couvercle espion ø61.8
7	2	2	2	2	2	2	2	2	2	2	2	2	P1.054.007	Coperchio	Cover	Deckel	Tapa	Couvercle
8	-	-	-	-	-	-	-	-	-	-	-	1	P1.067.006	Albero "PM" F	Shaft "PM" F	Welle "PM" F	Eje "PM" F	Arbre "PM" F
9	-	-	-	-	-	-	-	-	-	-	-	1	P1.067.007	Albero "PM" G	Shaft "PM" G	Welle "PM" G	Eje "PM" G	Arbre "PM" G
10	-	-	-	-	-	-	-	-	-	-	-	1	P1.067.008	Albero "PM" H	Shaft "PM" H	Welle "PM" H	Eje "PM" H	Arbre "PM" H
11	-	-	-	-	-	-	-	-	-	-	-	1	P1.067.009	Albero "PM" I	Shaft "PM" I	Welle "PM" I	Eje "PM" I	Arbre "PM" I
12	-	-	-	-	-	-	-	-	-	-	-	1	P1.067.011	Albero "PM" M	Shaft "PM" M	Welle "PM" M	Eje "PM" M	Arbre "PM" M
13	1	-	-	-	-	-	-	-	-	-	-	-	P1.067.012	Albero "PM" N	Shaft "PM" N	Welle "PM" N	Eje "PM" N	Arbre "PM" N
14	-	1	-	-	-	-	-	-	-	-	-	-	P1.067.013	Albero "PM" O	Shaft "PM" O	Welle "PM" O	Eje "PM" O	Arbre "PM" O
15	3	3	3	3	3	3	3	3	3	3	3	3	P1.071.002	Pistone ø18x40	Piston ø18x40	Kolben ø18x40	Pistón ø18x40	Piston ø18x40
17	1	1	1	1	1	1	1	1	1	1	1	1	P2.012.004	Coperchio PM	Cover PM	Deckel PM	Tapa PM	Couvercle PM
18	1	1	1	1	1	1	1	1	1	1	1	1	P2.013.021	Tappo 1/2" GAS	Cap 1/2" GAS	Deckel 1/2" GAS	Tapón 1/2" GAS	Bouchon 1/2" GAS
19	1	1	1	1	1	1	1	1	1	1	1	1	P2.013.022	Tappo 3/8" GAS	Cap 3/8" GAS	Deckel 3/8" GAS	Tapón 3/8" GAS	Bouchon 3/8" GAS
20	1	1	1	1	1	1	1	1	1	1	1	1	P2.035.002	Testata pompa PM	Pump head PM	Pumpekopf PM	Cabeza bomba PM	Tete de pompe PM
21	8	8	8	8	8	8	8	8	8	8	8	8	P2.119.001	Vite M8X60	Screw M8X60	Schrauben M8X60	Tornillo M8X60	Vis M8X60
22	3	3	3	3	3	3	3	3	3	3	3	3	P2.119.008	Dado M8X1	Nut M8X1	Mutter M8X1	Dado M8X1	Ecrou M8X1
23	3	3	3	3	3	3	3	3	3	3	3	3	P2.150.002	Biella PM	Connecting rod PM	Plenelstange PM	Biela PM	Bielle PM
24	8	8	8	8	8	8	8	8	8	8	8	8	P4.002.004	Vite M6x16 UNI5931	Screw M6x16 UNI5931	Schrauben M6x16 UNI5931	Tornillo M6x16 UNI5931	Vis M6x16 UNI5931
25	4	4	4	4	4	4	4	4	4	4	4	4	P4.002.010	Vite M6x20 UNI 5931-67	Screw M6x20 UNI 5931-67	Schrauben M6x20 UNI 5931-67	Tornillo M6x20 UNI 5931-67	Vis M6x20 UNI 5931-67
26	6	6	6	6	6	6	6	6	6	6	6	6	P4.002.013	Vite VITE TCEI M6x30	Screw VITE TCEI M6x30	Schrauben VITE TCEI M6x30	Tornillo VITE TCEI M6x30	Vis VITE TCEI M6x30
27	1	1	1	1	1	1	1	1	1	1	1	1	P4.005.010	OR 3.53x55.56	O-ring 3.53x55.56	O-Ring 3.53x55.56	OR 3.53x55.56	Joint torique 3.53x55.56
28	1	1	1	1	1	1	1	1	1	1	1	1	P4.015.001	Anello 25x62x10	Ring 25x62x10	Ring 25x62x10	Anillo 25x62x10	Bague 25x62x10
29	3	3	3	3	3	3	3	3	3	3	3	3	P4.015.002	Anello 16x24x5 NBR	Ring 16x24x5 NBR	Ring 16x24x5 NBR	Anillo 16x24x5 NBR	Bague 16x24x5 NBR
30	2	2	2	2	2	2	2	2	2	2	2	2	P4.016.002	Cuscinetto 6305	Bearing 6305	Kugellager 6305	Rodamiento 6305	Roulement 6305
31	1	1	1	1	1	1	1	1	1	1	1	1	P4.021.001	Chiavetta 8x7x35	Key 8x7x35	Keil 8x7x35	Chaveta 8x7x35	Clavette 8x7x35
32	1	1	1	1	1	1	1	1	1	1	1	1	P4.025.001	Seeger A25	Seeger A25	Seeger A25	Seeger A25	Seeger A25

PM Drawing

Disegno PM

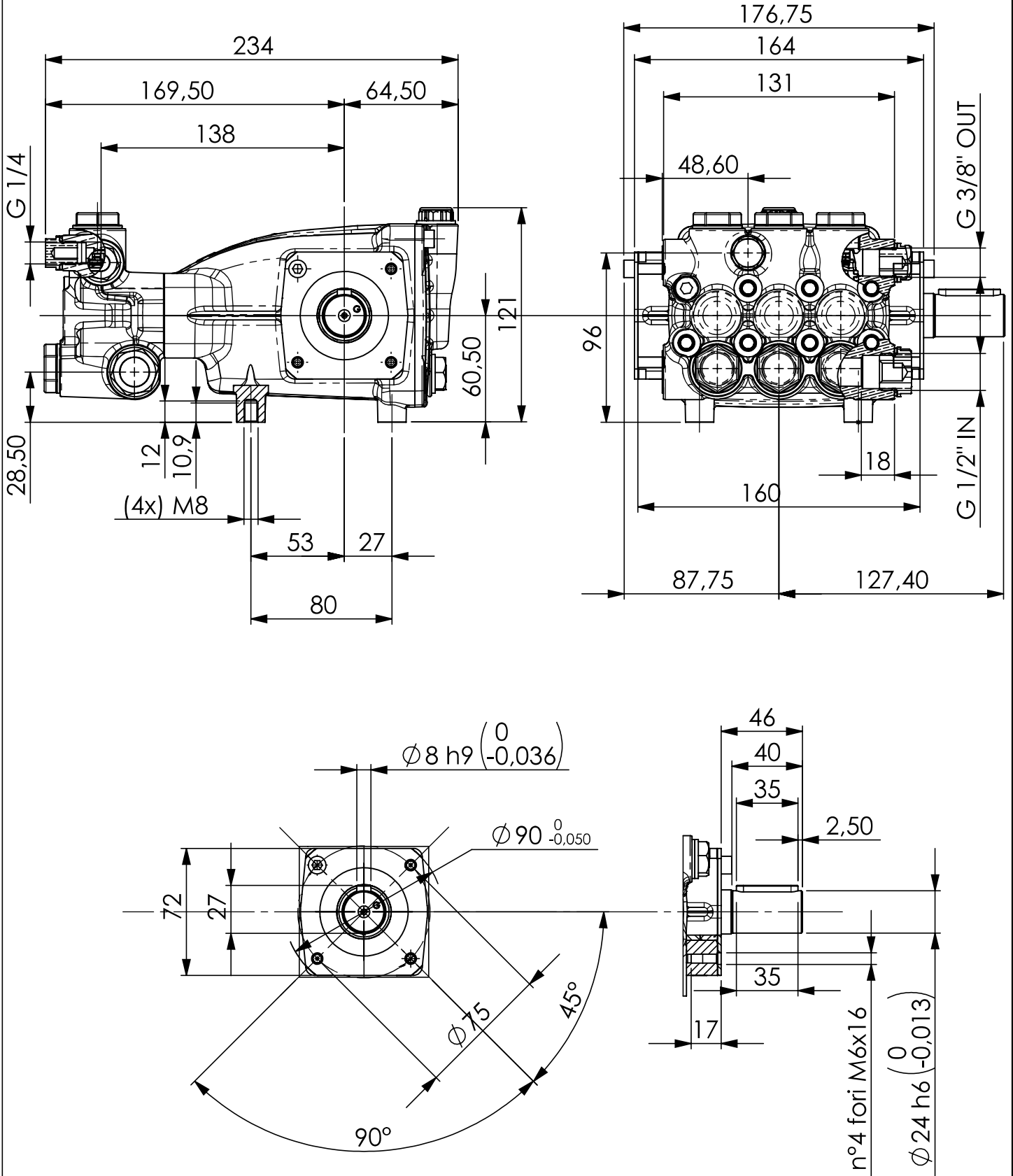

Pump head PM

Testata pompa PM



Use LOCTITE 270.
**TIGHTENING TORQUE
40Nm**

Spare parts
P9.003.003

Spare parts
P9.001.002

**TIGHTENING
TORQUE 25Nm**

Use LOCTITE 270.
**TIGHTENING TORQUE
40Nm**

Spare parts
P9.001.002

P2.035.002.B
Spare parts P9.040.002

Pos.	Q.ty	Code	ITALIANO	ENGLISH	DEUTSCH	ESPAÑOL	FRANCAIS
1	1	P1.012.002	Tappo 1/4"Gas	Cap 1/4"Gas	Deckel 1/4"Gas	Tapón 1/4"Gas	Bouchon 1/4"Gas
2	3	P1.024.002	Diffusore ø18 "PM"	Diffusor ø18 "PM"	Diffusor ø18 "PM"	Difusor ø18 "PM"	Diffuseur ø18 "PM"
3	1	P1.043.002	Testata pompa PM	Pump head PM	Pumpekopf PM	Cabeza bomba PM	Tete de pompe PM
4	6	P2.003.002	Valvola VAM ø20	Valve VAM ø20	Ventil VAM ø20	Válvula VAM ø20	Valve VAM ø20
5	6	P2.013.002	Tappo M22x1.5 + OR2075	Cap M22x1.5 + OR2075	Deckel M22x1.5 + OR2075	Tapón M22x1.5 + OR2075	Bouchon M22x1.5 + OR2075
6	3	P2.118.001	Pressore PM	Pressure Ring PM	Bague de pression PM	Anillo de presión PM	Bague de pression PM
6.1	1	P4.100.003	Tenuta pistone posteriore ø18xø28x8	Piston seal back ø18xø28x8	Kolbendichtung zurück ø18xø28x8	Pistón sellado posterior ø18xø28x8	Piston joint arrière ø18xø28x8
6.2	1	P4.005.012	OR 2112	O-ring 2112	O-Ring 2112	OR 2112	Joint torique 2112
7	6	P4.005.009	OR 3062	O-ring 3062	O-Ring 3062	OR 3062	Joint torique 3062
8	1	P4.008.007	Rondella Rame 1/4 Ø13x19x1.5	Copper washer 1/4 Ø13x19x1.5	Kupferunterlegsscheib e 1/4 Ø13x19x1.5	Arandela de cobre 1/4 Ø13x19x1.5	Rondelle cuivre 1/4 Ø13x19x1.5
9	3	P4.100.004	Tenuta pistone anteriore ø18xø28x10	Front piston seal ø18xø28x10	Front Kolbendichtung ø18xø28x10	Junta del pistón delantero ø18xø28x10	Joint de piston avant ø18xø28x10

Connecting rod PM

Biella PM

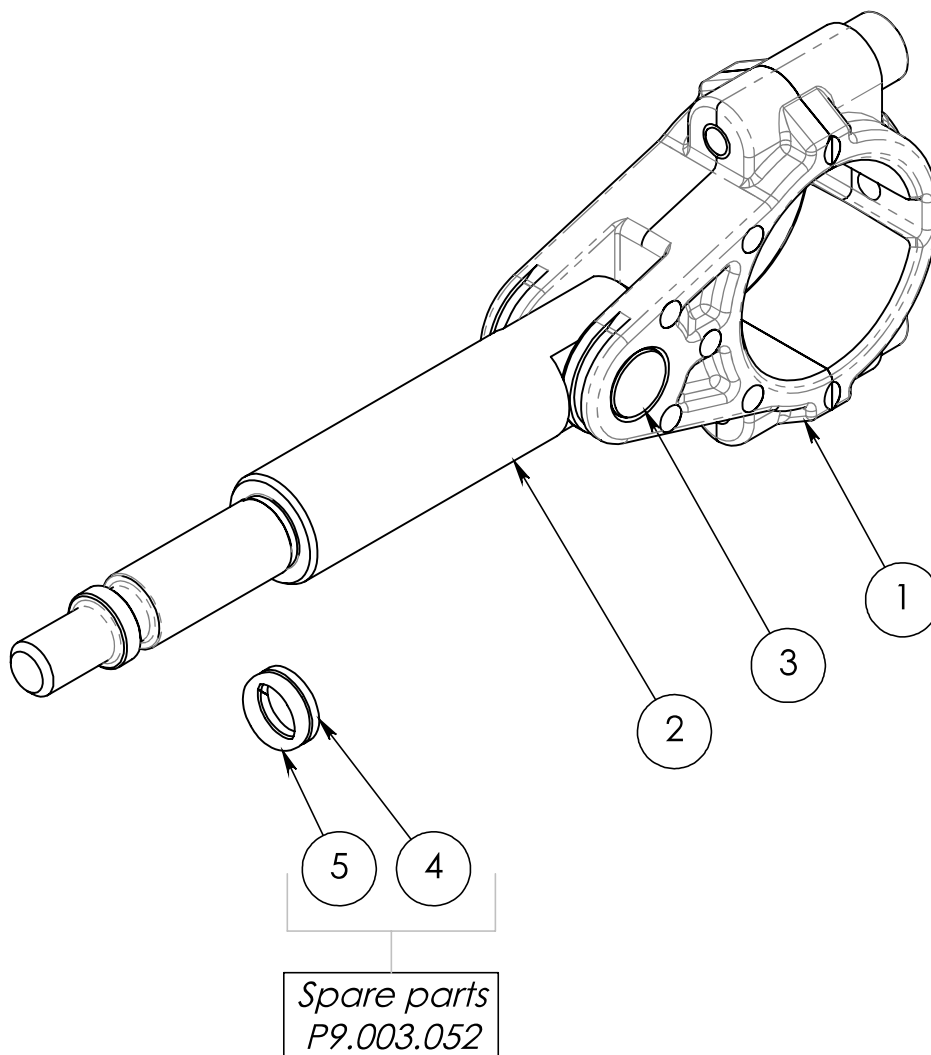

P2.150.002.A

Spare parts P9.041.002

Pos.	Q.ty	Code	ITALIANO	ENGLISH	DEUTSCH	ESPAÑOL	FRANCAIS
2	1	P1.010.002	Asta PM	Pole PM	Pfosten PM	Asta PM	Tige PM
3	1	P1.013.002	Spina cilindrica ø10x20	Cylindrical pin ø10x20	Zylinder Stift ø10x20	Pasador cilindrico ø10x20	Goupille cylindrique ø10x20
4	1	P1.027.001	Anello 11x8.3x1.3	Ring 11x8.3x1.3	Ring 11x8.3x1.3	Anillo 11x8.3x1.3	Bague 11x8.3x1.3
1	1	P1.099.001	Biella PM	Connecting rod PM	Plenelstange PM	Biela PM	Bielle PM
5	1	P4.005.004	OR 2031	O-ring 2031	O-Ring 2031	OR 2031	Joint torique 2031

Cover PM

Coperchio PM

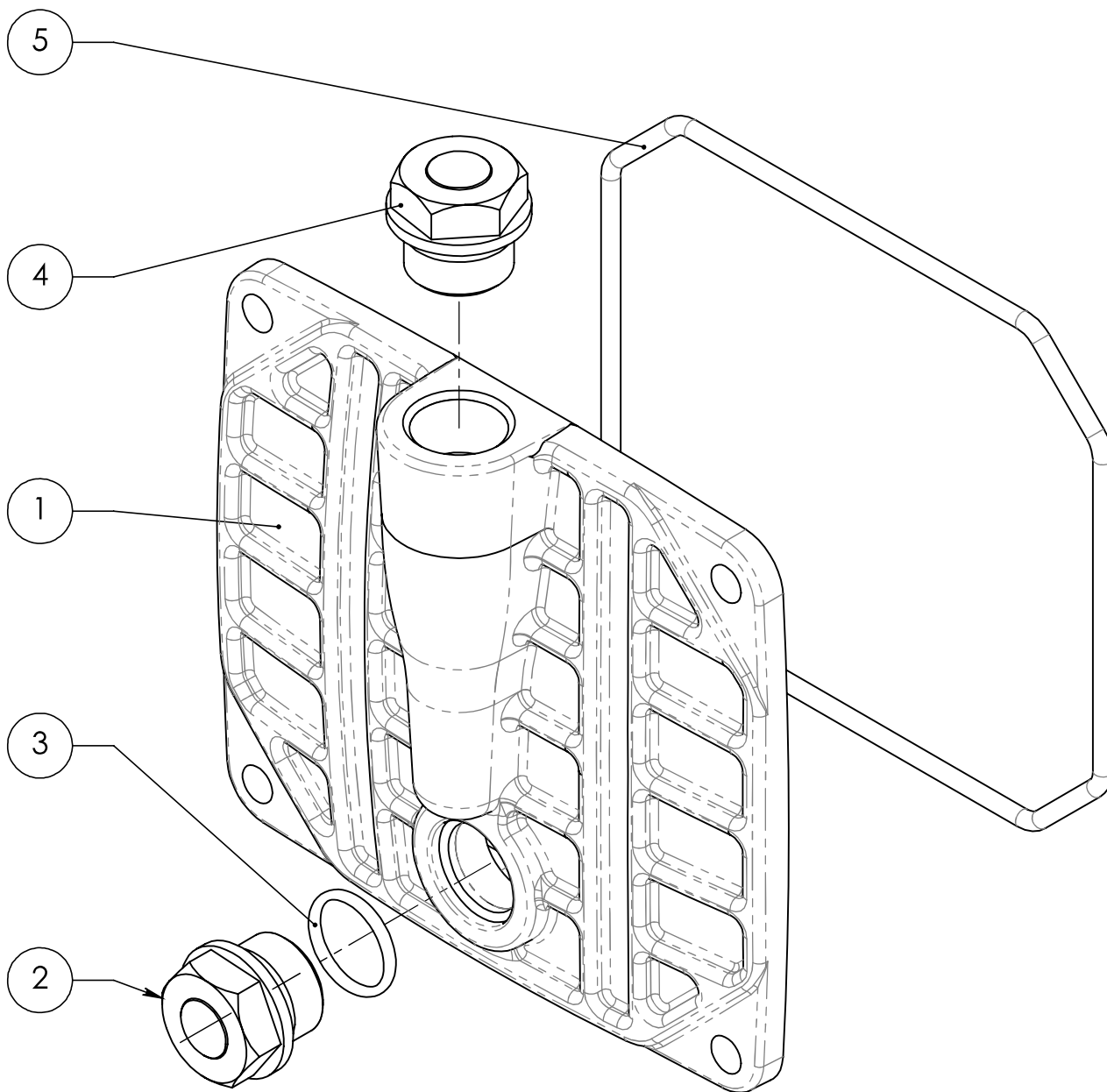

P2.012.004.B

Pos.	Q.ty	Code	ITALIANO	ENGLISH	DEUTSCH	ESPAÑOL	FANCAIS
1	1	P1.054.004	Coperchio "PM"	Cover "PM"	Deckel "PM"	Tapa "PM"	Couvercle "PM"
2	1	P1.012.003	Tappo G 3/8" H18	Cap G 3/8" H18	Deckel G 3/8" H18	Tapón G 3/8" H18	Bouchon G 3/8" H18
3	1	P4.005.007	Guarnizione OR 2056 14x1.78NBR 70Sh	Gasket OR 2056 14x1.78NBR 70Sh	Dichtung OR 2056 14x1.78NBR 70Sh	Guarnición OR 2056 14x1.78NBR 70Sh	Garniture OR 2056 14x1.78NBR 70Sh
4	1	P1.012.007	Tappo 3/8	Cap 3/8	Deckel 3/8	Tapón 3/8	Bouchon 3/8
5	1	P4.005.031	OR ORM1070-30 (107x3) NBR	O-ring ORM1070-30 (107x3) NBR	O-Ring ORM1070-30 (107x3) NBR	OR ORM1070-30 (107x3) NBR	Joint torique ORM1070-30 (107x3) NBR

Spare parts

Ricambi

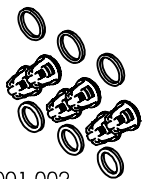

P9.001.002
VALVOLA COMPLETA POMPA PM - KIT VALVES

Code	Q.Ty	ITALIANO	ENGLISH	DEUTSCH	ESPAÑOL	FRANCAIS
P2.003.002	6	Valvola VAM ø20	Valve VAM ø20	Ventil VAM ø20	Válvula VAM ø20	Valve VAM ø20
P4.005.008	6	OR 2075	O-ring 2075	O-Ring 2075	OR 2075	Joint torique 2075
P4.005.009	6	OR 3062	O-ring 3062	O-Ring 3062	OR 3062	Joint torique 3062



P9.003.003
GUARNIZIONE PISTONE ø18 POMPA PM - KIT PLUNGER SEALS

Code	Q.Ty	ITALIANO	ENGLISH	DEUTSCH	ESPAÑOL	FRANCAIS
P4.005.012	3	OR 2112	O-ring 2112	O-Ring 2112	OR 2112	Joint torique 2112
P4.100.003	3	Tenuta pistone posteriore ø18Xø26X8	Piston seal back ø18Xø26X8	Kolbendichtung zurück ø18Xø26X8	Piston sellado posterior ø18Xø26X8	Piston joint arrière ø18Xø26X8
P4.100.004	3	Tenuta pistone anteriore ø18Xø28X10	Front piston seal ø18Xø28X10	Front Kolbendichtung ø18Xø28X10	Junta del pistón delantero ø18Xø28X10	Joint de piston avant ø18Xø28X10



P9.003.004
GUARNIZIONE PISTONE ø18 POMPA PM PACCO COMPLETO - KIT COMPLETE SEALS

Code	Q.Ty	ITALIANO	ENGLISH	DEUTSCH	ESPAÑOL	FRANCAIS
P1.024.002	1	Diffusore ø18 "PM"	Diffuser ø18 "PM"	Diffusor ø18 "PM"	Difusor ø18 "PM"	Diffuseur ø18 "PM"
P1.070.002	1	Pressore PMø18	Pressure Ring PMø18	Bague de pression PMø18	Anillo de presión PMø18	Bague de pression PMø18
P4.005.012	1	OR 2112	O-ring 2112	O-Ring 2112	OR 2112	Joint torique 2112
P4.100.003	1	Tenuta pistone posteriore ø18Xø26X8	Piston seal back ø18Xø26X8	Kolbendichtung zurück ø18Xø26X8	Piston sellado posterior ø18Xø26X8	Piston joint arrière ø18Xø26X8
P4.100.004	1	Tenuta pistone anteriore ø18Xø28X10	Front piston seal ø18Xø28X10	Front Kolbendichtung ø18Xø28X10	Junta del pistón delantero ø18Xø28X10	Joint de piston avant ø18Xø28X10



P9.004.002
PISTONE ø18 POMPA PM - KIT CERAMIC PISTON

Code	Q.Ty	ITALIANO	ENGLISH	DEUTSCH	ESPAÑOL	FRANCAIS
P1.003.001	1	Rondella Rame ø23.5xø11.2x0.5	Copper washer ø23.5xø11.2x0.5	Kupferunterlegsscheibe ø23.5xø11.2x0.5	Arandela de cobre ø23.5xø11.2x0.5	Rondelle cuivre ø23.5xø11.2x0.5
P1.027.001	1	Anello 11x8.3x1.3	Ring 11x8.3x1.3	Ring 11x8.3x1.3	Anillo 11x8.3x1.3	Bague 11x8.3x1.3
P1.035.001	1	Dado M8x1	Nut M8x1	Mutter M8x1	Dado M8x1	Ecrou M8x1
P1.071.002	1	Pistone ø18x40	Piston ø18x40	Kolben ø18x40	Pistón ø18x40	Piston ø18x40
P4.005.004	1	OR 2031	O-ring 2031	O-Ring 2031	OR 2031	Joint torique 2031
P4.008.010	1	Rondella Rame ø11.2xø15x0.5	Copper washer ø11.2xø15x0.5	Kupferunterlegsscheibe ø11.2xø15x0.5	Arandela de cobre ø11.2xø15x0.5	Rondelle cuivre ø11.2xø15x0.5



P9.039.001
ANELLI TENUTA OLIO ASTA POMPA MM-PM - KIT OIL SEALS

Code	Q.ty	ITALIANO	ENGLISH	DEUTSCH	ESPAÑOL	FRANCESE
P4.015.002	3	Anello 16x24x5 NBR	Ring 16x24x5 NBR	Ring 16x24x5 NBR	Anillo 16x24x5 NBR	Bague 16x24x5 NBR

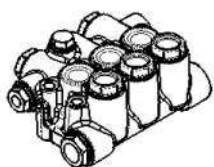

P9.040.002
TESTATA COMPLETA PISTONE ø18 POMPA PM - COMPLETE HEAD OF THE PUMP

Code	Q.Ty	ITALIANO	ENGLISH	DEUTSCH	ESPAÑOL	FRANCAIS
P2.013.021	1	Tappo 1/2" GAS	Cap 1/2" GAS	Deckel 1/2" GAS	Tapón 1/2" GAS	Bouchon 1/2" GAS
P2.013.022	1	Tappo 3/8" GAS	Cap 3/8" GAS	Deckel 3/8" GAS	Tapón 3/8" GAS	Bouchon 3/8" GAS
P2.035.002	1	Testata pompa PM	Pump head PM	Pumpekopf PM	Cabeza bomba PM	Tete de pompe PM
P4.043.001	1	Protezione ø20	Protection ø20	Scuhtz ø20	Protección ø20	Protection ø20
P4.043.002	1	Protezione 15.5	Protection 15.5	Scuhtz 15.5	Protección 15.5	Protection 15.5

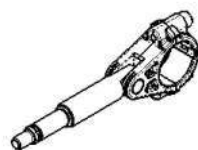

P9.041.002
BIELLA -ASTA POMPA PM - PREASSEMBLED CONNECTING ROD

Code	Q.Ty	ITALIANO	ENGLISH	DEUTSCH	ESPAÑOL	FRANCAIS
P2.150.002	1	Biella PM	Connecting rod PM	Plenelstange PM	Biela PM	Bielle PM
P4.002.013	2	Vite VITE TCEI M6x30	Screw VITE TCEI M6x30	Schrauben VITE TCEI M6x30	Tornillo VITE TCEI M6x30	Vis VITE TCEI M6x30



P9.003.052
GUARNIZIONE BIELLA ø11 POMPA PM - KIT CONNECTING ROD SEALS

Code	Q.Ty	ITALIANO	ENGLISH	DEUTSCH	ESPAÑOL	FRANCAIS
P1.027.001	1	Anello 11x8.3x1.3	Ring 11x8.3x1.3	Ring 11x8.3x1.3	Anillo 11x8.3x1.3	Bague 11x8.3x1.3
P4.005.004	1	OR 2031	O-ring 2031	O-Ring 2031	OR 2031	Joint torique 2031



MASSIMA TEMPERATURA INGRESSO ACQUA
MAX INPUT WATER TEMPERATURE

65°C
149°F

PRESSIONE MINIMA INGRESSO
MINIMAL INPUT PRESSURE

0.2 BAR
2.9 PSI

INGRESSO
INLET

G 1/2"

USCITA
OUTLET

G 3/8"



PM	PORTATA FLOW RATE		GIRI ROUNDS		PRESSIONE MASSIMA MAX PRESSURE		CAPACITÀ OLIO OIL CAPACITY		PESO WEIGHT	
	Lt/min	Gpm	Rpm		Bar	Psi	Lt	Gal	kg	Lbs
50HZ	8.50 » 15.00	2.24 » 3.96	1450		170	2465	0.4	0.1	7.5	16.53
60HZ	10.20 » 18.00	2.69 » 4.75	1740							

Codice Code	Modello Model	Portata / Flow Rate lt/min - gpm		Pressione / Pressure		Potenza / Power		Albero Shaft L: 40mm Ø 24		
		1450 rpm	1740 rpm	Bar	Psi	50Hz HP	60Hz HP			
P3.010.002	PM8170R	8.50	2.24	170.00	2465	3.75	2.80	4.50	3.36	Destra / Right
P3.010.003	PM10170R	10.00	2.64	170.00	2465	4.42	3.30	5.30	3.95	Destra / Right
P3.010.004	PM11170R	11.00	2.91	170.00	2465	4.86	3.62	5.83	4.35	Destra / Right
P3.010.005	PM12170R	12.00	3.17	170.00	2465	5.30	3.95	6.36	4.75	Destra / Right
P3.010.006	PM13170R	13.00	3.43	170.00	2465	5.74	4.28	6.89	5.14	Destra / Right
P3.010.007	PM14170R	14.00	3.70	170.00	2465	6.18	4.61	7.42	5.54	Destra / Right
P3.010.008	PM15170R	15.00	3.96	170.00	2465	6.62	4.94	7.95	5.93	Destra / Right
P3.010.009	PM8170L	8.50	2.24	170.00	2465	3.75	2.80	4.50	3.36	Sinistra / Left
P3.010.010	PM10170L	10.00	2.64	170.00	2465	4.42	3.30	5.30	3.95	Sinistra / Left
P3.010.011	PM11170L	11.00	2.91	170.00	2465	4.86	3.62	5.83	4.35	Sinistra / Left
P3.010.012	PM12170L	12.00	3.17	170.00	2465	5.30	3.95	6.36	4.75	Sinistra / Left
P3.010.013	PM13170L	13.00	3.43	170.00	2465	5.74	4.28	6.89	5.14	Sinistra / Left
P3.010.014	PM14170L	14.00	3.7	170.00	2465	6.18	4.61	7.42	5.54	Sinistra / Left
P3.010.008	PM15170L	15.00	3.96	170.00	2465	6.62	4.94	7.95	5.93	Sinistra / Left

RICAMBI / SPARE PARTS

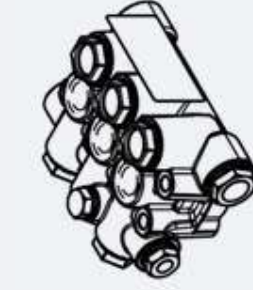

KIT - P9.039.001
ANELLI TENUTA OLIO ASIA
KIT OIL SEAL PUMP MM PM



KIT - P9.003.003
GUARNIZIONE PISTONE
KIT PLUNGERS SEALS



KIT - P9.040.002
TESTATA COMPLETA
COMPLETE HEAD OF THE PUMP



KIT - P9.004.002
PISTONE Ø18 POMPA PM
KIT CERAMIC PISTON



KIT - P9.003.004
GUARNIZIONE PISTONE Ø18 - PACCO COMPLETO
KIT COMPLETE SEALS



KIT - P9.041.002
PREMONTATO BIELLA - ASTA
PREASSEMBLED CONNECTING ROD

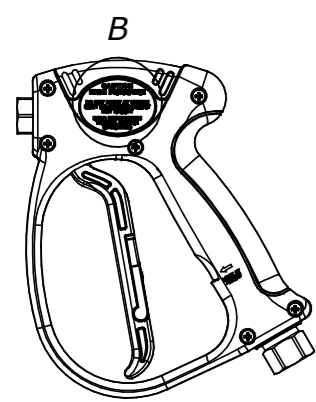

DETTAGLIO-DETAIL B

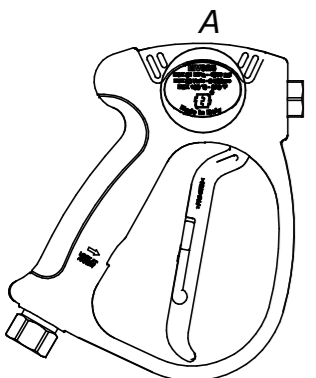

DETTAGLIO-DETAIL A

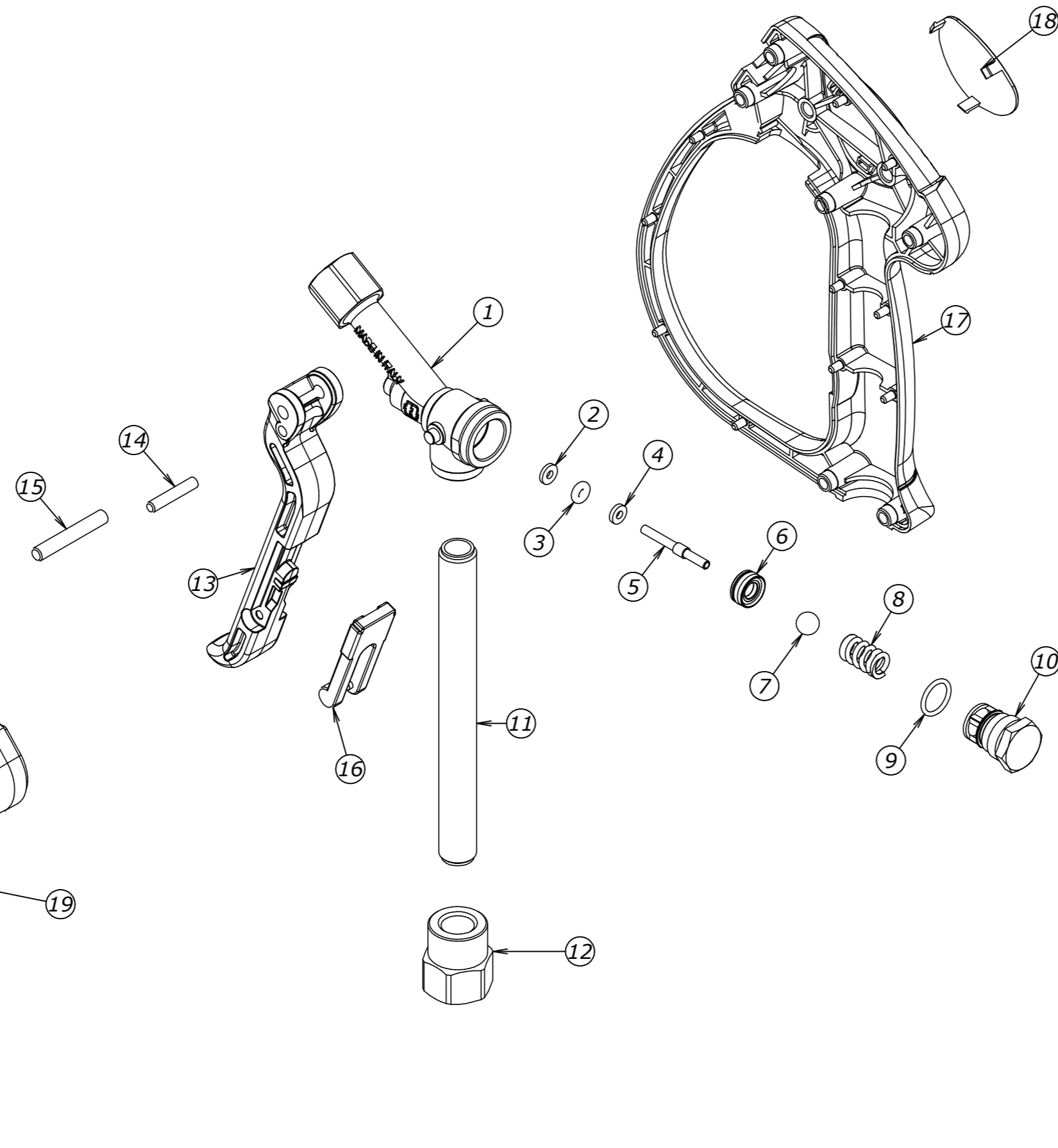
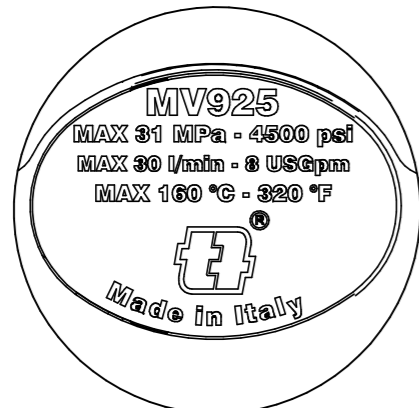

Num.	Codice	Descrizione Completa	Quant.	Kit1	Kit2	Kit3
1	C00015011	CORPO MV925 G 1/4 F	1			
2	000117	A.A. 3,00x 7,40x1,30 TB	1	X		
3	060143	GUOR 2.62X2.84 104 VITON 75 NERO	1	X		
4	R00300014	RONDELLA 3 X 7 X 1,5 OTTONE	1	X		
5	P00004004	PERNO PREMISFERA MV925	1	X		
6	0106200140	SEDE MV2001 CONIATA CON OR NBR 90	1	X		
7	160013	SFERA 5/16 G28 AISI 420C HRC 56 MIN	1	X		
8	M00201052	MOLLA INOX 1,7 X 9,4 X 16,5	1			
9	0110750700	GUOR 1.5X11 NBR 90 NERO	1	X		
10	T00000096	TAPPO MV 925 VERS. STANDARD	1			
11	T00303044	TUBO L.130 MM ZINCATO G 1/4 M	1			
12	R00000212	RACCORDO ENTR. OTT G 3/8 F	1			
13	L00002049	LEVA MV 925 NERA	1		X	
14	P00004005	PERNO PER LEVA MV925 D.4X22 INOX	1		X	
15	P00000087	PERNO PER LEVA MV925 D.5X33 IX	1		X	
16	0100740520	SICURA MV951- ROSSA -	1		X	
17	S02301247	SCOCCA MV 925 DESTRA NERA	1			X
18	T00200169	TARGHETTA MV 925 DESTRA ROSSA	1			X
19	S02301248	SCOCCA MV 925 SINISTRA NERA	1			X
20	0116730010	VITE AUTOF. 4 X 19 UNI 9707	6			X
21	T00200170	TARGHETTA MV 925 SINISTRA ROSSA	1			X

KIT 1 - KIT RICAMBI SEDE GUARNIZIONI - REPAIR KIT SEAT GASKET Cod. 4019900025
 KIT 2 - KIT RICAMBI LEVA COMPLETA - REPAIR KIT TRIGGER Cod. 4019900026
 KIT 3 - KIT RICAMBI SCOCHE E VITI - REPAIR KIT SHELL SCREW Cod. 4019900029

DENOMINAZIONE - TITLE MV925 G 3/8 F - G 1/4 F		CODICE CLIENTE - CUSTOMER PART NO.		DISEGN. DWN VISTO APPROVED DATA DATE CODICE - PART NO. REV.	Campelli RF 15/03/13 4012205000 0
VIETATO RIPRODURRE O DIVULGARE IN TUTTO O IN PARTE IL PRESENTE DISEGNO SENZA AUTORIZZAZIONE SCRITTA DELLA TECOMECC S.p.A. IT IS FORBIDDEN TO PARTIALLY OR TOTALLY COPY, USE OR DISCLOSE THIS MATERIAL WITHOUT PRIOR WRITTEN CONSENT FROM TECOMECC S.p.A.		42124-REGGIO EMILIA - ITALY			

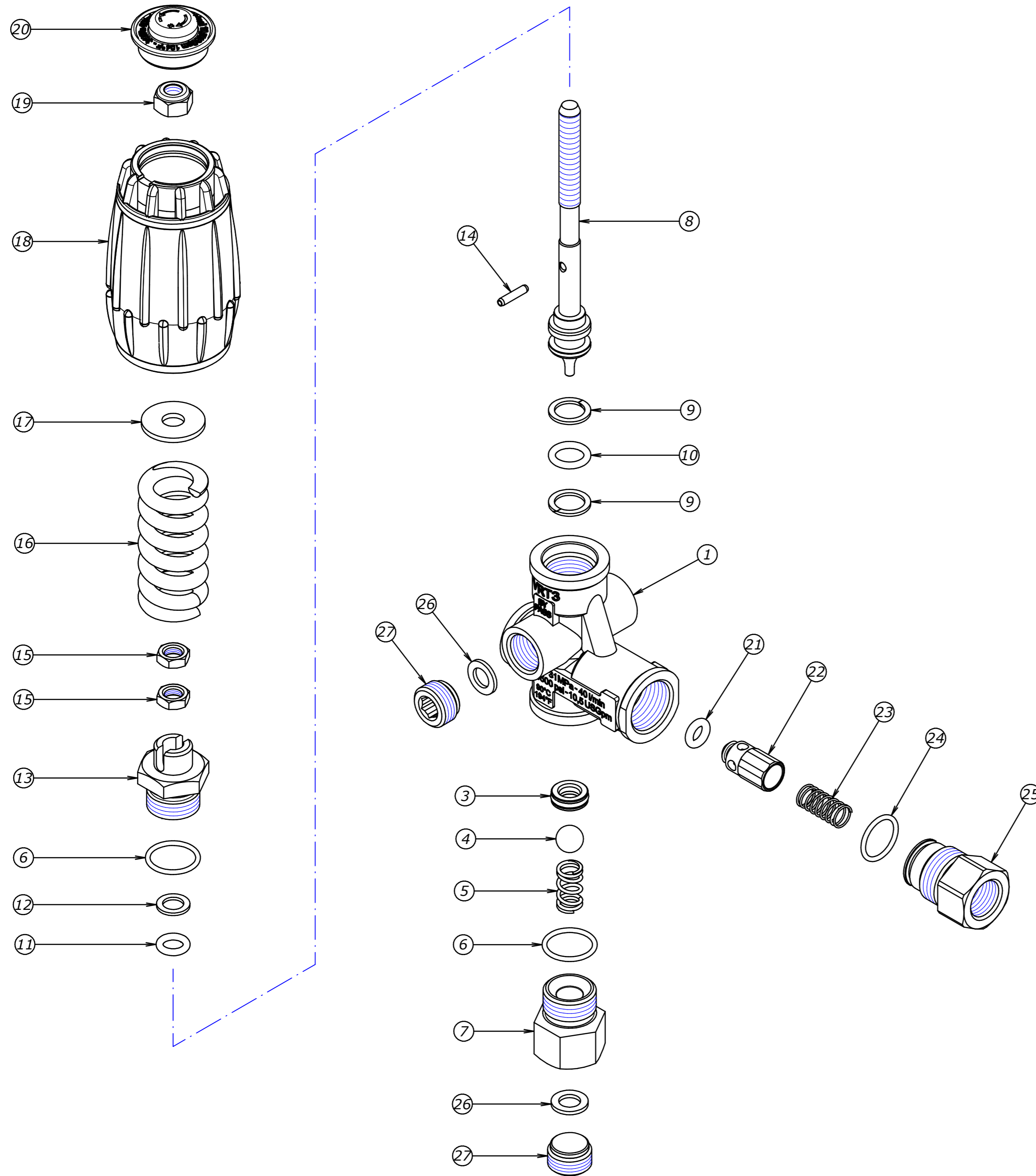

Num.	Codice	Descrizione Completa	Quant.	Kit
1	0109712650	CORPO VRT3 G 3/8 F MV 0316 01B	1	
3	4079500001	SEDE VRT3 Ø8 CONIATA CON OR NBR 90	1	X
4	0112720010	SFERA DIAM.13/32 AISI 440C TEMP G20	1	X
5	0107720820	MOLLA SFERA MV 0316 28	1	
6	0110751311	GUOR 1.78X17.17 2068 NBR 90 NERO	2	X
7	0115712280	RAC.SEDE3/8GF SF13/32' MV 0316 15A	1	
8	0104720230	STELO VRT3 MV 0316 04	1	
9	000125	A.A.11,50x15,9x1,20 TBT 000125B	2	X
10	0110750910	GUOR 2.62X10.78 3043 NBR 70 NERO	1	X
11	0110750170	GUOR 2.62X7.6 3030 NBR 70 NERO	1	X
12	0122790030	A.A.8X12,6X1,2 MV 0316 05	1	X
13	0115712250	RAC.GUIDA STELO VRT3 MV 0316 06	1	
14	0118720120	SPINA ELASTICA UNI ISO 28748 - 3X14	1	
15	030200	DADO VRT-VHP M 8 x 4 OTT.	2	
16	0107770080	MOLLA 5,7X20,7X56 31 MPA MV 0316 19	1	
17	150204	RONDELLA D. 8,5x24,0x2,0 Z.B.	1	
18	400305	MANOPOLA VRT2-VHP ROHS	1	
19	030101	DADO AUTOBLOC.BASSO M8x8 Z.B.	1	
20	0128740090	COPERCHIO MAN.31MPA MV 0316 22	1	
21	060109	GUOR 3.0X6.0 NBR 90 NERO	1	X
22	0157710040	OTTURATORE VRT3 MV 0316 07	1	
23	0107720800	MOLLA OTTURATORE VRT3 MV 0316 08A	1	
24	0110751321	GUOR 1.78X15.6 2062 NBR 90 NERO	1	X
25	0115712260	RACCORDO RITEGNO G3/8 F	1	
26	060200	GUARNIZIONE D.14 x8,3x1,5 RAME	2	
27	170101	TAPPO E.I. G3/8 CILINDRICO OTTONE	2	

KIT RICAMBIO VRT3 - 31 MPa - - - Cod. 4079900005

DENOMINAZIONE - TITLE VRT3 G 3/8 F - 31 MPA + MANOPOLA		CODICE CLIENTE - CUSTOMER PART NO.	
VIETATO RIPRODURRE O DIVULGARE IN TOTO O IN PARTE IL PRESENTE DISEGNO SENZA AUTORIZZAZIONE SCRITTA DELLA TECOMECC S.p.A. IT IS FORBIDDEN TO PARTIALLY OR TOTALLY COPY, USE OR DISCLOSE THIS MATERIAL WITHOUT PRIOR WRITTEN CONSENT FROM TECOMECC S.p.A.			
		CODICE - PART NO.	REV.
		0215010260	3