

# High Pressure Cold Water Jet Machine

## Operating Manual

Model: SKY1525CET-SS

Series: Transformer

Pressure: 250 Bar

Flow: 15 Lpm



# SKY TECH

AND CLEANING SYSTEMS PVT.LTD.

Touching New Horizon



+91 96192 68086

[sales@skyengg.in](mailto:sales@skyengg.in)

[www.skytechcleaning.com](http://www.skytechcleaning.com)

 Unit No. 1, Behind Reliable Tech Park, Gavate Compound, Airoli (E), Navi Mumbai 400708

## 1. INTRODUCTION

The horizontal Plunger Pumps are designed and manufactured to pump or transfer **water**. They are generally driven by: electric motors, endothermic petrol or diesel engines and hydraulic motors, tractor P.T.O... Couplings may be fulfilled by means of transmission shaft, direct flanging, reduction unit or multiplier, joints, pulleys and belts.

The Pumps are supplied standard with the power take-off of the shaft on the right, looking at the Pump from the head (see fig.1). On request, all Pump models can be supplied with power take-off on the left.



**The Pump is supplied to be installed on a more complex machine or plant; the manufacturer of such machine or plant shall add all the information related to safety of the assembled machine/plant fulfilled.**

## 2. INTENDED USE

Plunger Pumps are designed to be used in machines or systems for transferring pressurized water, such as the following for example: Car Wash, Civil and Industrial Washing Systems, Road Washers and Bin Washers, Water Treatment, Misting, Drain and Pipe Cleaning and Fire-fighting.

The temperature of the workplace shall be between: Min. 0°C (32°F) - Max. 45°C (113°F)

The Pump cannot be used submerged under any type of liquid.

## 3. OPERATIONAL RESTRICTION

The specifications of the liquid to be used are described in detail herewith: do not use for different liquids; in particular, it is NOT possible to use Pumps in the following conditions:



- In the presence of water with high salt content, such as seawater for example; for this type of use, you are recommended to use Pump stainless steel series.
- In workplaces where there is a corrosive or explosive atmosphere.
- In the presence of any liquid that is not compatible with the constructional material of the Pump.
- To pump paint, solvents, fuel and any flammable liquid (not suitable for ATEX workplaces).
- To foodstuffs.
- To wash people, animals, live electrical or electronic equipment.
- To wash the Pump itself.

## 4. GENERAL WARNING



- Never start the Pump under pressure.
- Constantly check the state of wear of the pipes and relevant fittings, especially those under pressure. Pipes with signs of abrasion or that do not guarantee a perfect seal shall be replaced.
- The Pump must never run dry/without any liquid while in use.



- Protect rotating parts with a cover to prevent contact..
- The Pump is designed to be integrated in a machine or system, with various supply systems, which may make the noise level vary, even quite substantially. The manufacturer of such machine or system shall assess the level of noise emitted by the assembled machine or system and inform the user appropriately, also in relation to the use of suitable personal Protection equipment.

## 5. BEFORE START UP

### LIQUIDS TO BE PUMPED

The Pump is designed and manufactured to transfer clean liquid or non-aggressive watery solutions.

The liquid in taken must be free from sand or other solid particles in suspension.

The liquid in taken shall have viscosity and density similar to water.

The maximum temperature of the liquid to be pumped varies according to the conditions of the system (see section 6.3 - INLET CONDITIONS).

Any other use is not admitted unless authorized in writing by the Engineering Department of **SKY**.

### INLET AND OUTLET OF THE PUMP

The Inlet port for the liquid that must be pumped is generally located on the lower part of the Pump's

head and may also be called the suction port or supply port. The Outlet port for the pumped liquid is generally located on the upper part of the head and may also be called the delivery port. The Inlet and outlet ports may be used either on the right or the left side of the Pump's head, by dismantling or inverting the closure plugs.

 The Inlet and Outlet CANNOT be inverted.

**INLET CONDITIONS (SUCTION)**

Pump is mounted above the supply tank.	Pump is mounted below the supply tank in gravity feeding.	Pump is pressure fed.
Max. difference of level between Pump and supply tank: 0,5 m/1.6 ft.	Max. Pump speed: 1750 RPM.	Max. Inlet pressure: 6 bar (90 PSI).
Max. working pressure: 250 bar (3600 PSI).	Max. inlet water temperature up to 250 Bar (3600 PSI) of Working pressure: 50°C (122°F).	The feeding source must provide 50% more than the Pump flow.
Max inlet vacuum: -0.2 bar (-6 inch.Hg).		If a pressure feeding Pump is used, it must be started before the plunger Pump.
Max. Pump speed: 1450 RPM.	Max. Inlet water temperature over to 250 bar (3600 PSI) of working pressure: 35°C (95°F).	Max. Inlet water temperature: 50°C (122°F).
Max. Inlet water temperature: 40°C (104°F).		
<p>The inlet pipeline must comply with the following requirements:</p> <ul style="list-style-type: none"> <li>- Any point of the inlet pipeline cannot be smaller than the diameter of the Pump inlet.</li> <li>- Be absolutely leak-proof to avoid any air infiltration</li> <li>- Not have 90° bends near the Pump inlet.</li> <li>- Not have contractions or restrictions.</li> <li>- Avoid any turbulence near the Pump inlet and in the supply tank.</li> <li>- If an inlet filter is used, it must allow 200% more flow than the flow required by the Pump. It must not cause any contraction or any pressure drop. The filter should be grant a filtration degree between 50 and 80 meshes and should be cleaned on a regular basis to ensure its proper functionality.</li> </ul>		

Any other use is not admitted unless authorized in writing by the Engineering Department of SKY.

**OUTLET CONDITIONS**

Make sure the delivery line and all the accessories are connected correctly, secured firmly, hermetically sealed and that the pipes are sized appropriately. All pressurized pipes must be marked durably with the maximum admitted pressure, which must never be less than the maximum working pressure of the Pump, written on the Label

**SPEED AND ROTATION DIRECTION**

 The rotation speed of the shaft of the Pump must never exceed the RPM written on the Label of the actual Pump.

The minimum RPM admitted is: maximum RPM x 0.6.  
The rotation direction of the shaft of Pumps may be clockwise or anticlockwise.

## 6. CONTROLS ON SYSTEM

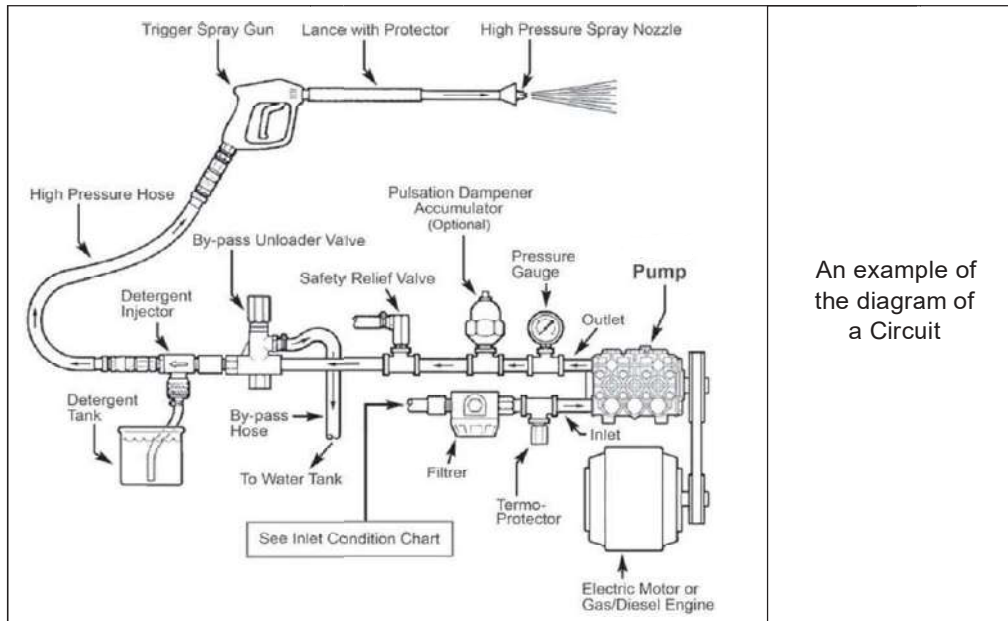

### UNLOADER VALVE

A pressure regulator valve must be installed to avoid the pressure exceeding the maximum limit indicated on the Label of the Pump.

 Use of the Pump, even for a short period, with a pressure higher than such limit would damage the Pump itself.

The regulator valve shall be compatible with the maximum pressure, flow rate and temperature values written on the Label and in the "INLET CONDITIONS".

 Incorrect installation of the pressure regulator valve could cause serious personal injuries and damage to property as well as seriously damaging the actual Pump.

The circuit must be equipped with another safety valve to prevent the maximum pressure from being exceeded in the case of anomalies in the pressure regulator valve.

### NOZZLE

A deteriorated nozzle could cause a drop in pressure; in this case, do not adjust the pressure regulator valve in the attempt to increase the pressure of the system because when the delivery line closes, this would cause a boost in pressure, which could damage the Pump.

If the pressure drops, it is advisable to replace the nozzle and adjust the system's pressure again. The flow rate of the Pump must be at least 10% higher than the flow rate that the utilities demand; the excess flow rate must be discharged.

### PULSATION DAMPENER (ACCUMULATOR)

For applications in which pulses produced by the Pump on the delivery line are harmful or undesired, install an appropriately sized pulse dampener.

### PRESSURE GAUGE

Install a gauge as near as possible to the outlet of the Pump because the maximum pressure written on the Pump's Label refers to the pressure detected on the head of the Pump and not on the nozzle or on other accessories.

 All the components of the machine or of the circuit must have technical specifications compatible

with the data written on the Pump's Label.

## 7. INSTALLATION, START UP AND SWITCHING OFF

### POSITIONING

Smaller and lighter Pumps can be handled by hand in compliance with current standards. Heavier Pumps must be handled using the dedicated hook and suitable lifting device. If there is no eyelet and you need to use a lifting device, use appropriate strap/s, being careful not to damage the product. The weight of the Pumps is written in the table on page 25.

If the Pump is used in particularly dirty workplaces or is exposed to atmospheric agents, you are recommended to protect it, respecting the ventilation conditions.

### ASSEMBLY

Fit the Pump on a rigid surface keeping the power take-off and support feet horizontal to ensure correct drainage in the case of leakage of water or oil. The Pump must be secured firmly on a base, which must be perfectly aligned with the transmission components. In the case of belt transmission, make sure the pulleys are aligned and check the tension of the belts.

Use appropriately sized hoses, both on the inlet and outlet of the Pump, according to the technical specifications written on the Label.

### START UP

Before starting, check the following:



**Replace the RED cap on the Pump Crankcase with the venting cap in the kit of accessories supplied.**

- Check the oil level through the dedicated oil reservoir or inspection cap; top-up if necessary.
- Check the pressure value on the accumulator, if installed; inflate or deflate if necessary.
- The pressure regulator valve must be set at "0" pressure to favour intake.

Start and run the Pump for approximately 10 seconds until all the liquid has discharged from the delivery line. Once the intake cycle is complete, you can set the Pump at the required pressure, by adjusting the pressure regulator valve, without ever exceeding the maximum pressure written on the Pump's Label.

### SWITCHING OFF AND STORAGE

After use or if the Pump is to be put away in storage, wash it internally. You can do this by running the Pump for several minutes with clean water, then disconnect the supply line and leave the Pump to run for approximately 15 seconds so that all the water in the head is discharged.

A few minutes devoted to the internal washing of the pump brings considerable benefits in terms of the pump's lifetime.



Do not wash the Pump externally: water could get into the Pump crankcase, for example through the oil vent cap.



After switching off, the Pump could remain very hot for some time.



Do not throw the liquid used to wash the Pump outdoors but observe current standards.

### PRECAUTIONS AGAINST FREEZING

If shutdown during winter or in the case of places and seasons subject to frost, once the Pump has finished working, run it for the time required to pump an emulsion of 50% of clean water and 50% of antifreeze fluid through it in order to prevent freezing and damage to the Pump.

The Pump must not be used to Pump antifreeze fluid that is not mixed with water.

**In the presence of ice or very cold temperatures at the workplace, the Pump must never be started;** otherwise the Pump could be seriously damaged. To start the system, the whole circuit must be completely defrosted.

## 8. MAINTENANCE

### ROUTINE MAINTENANCE

If the Pump is used for light-duty purposes, the following routine maintenance jobs are advised:

- After the first 50 hours: Oil change (see section 9.2 - Lubrication)
- Every 200 - 300 hours: Oil change (see section 9.2 - Lubrication)
- Every 1000 hours: Replace the valves - replace piston seal rings for heavy-duty purposes, carry out the maintenance jobs more often.



When inspecting or replacing the Pump valves, be careful which type of Loctite® you use on the caps over the valves (see table on page 26-27).

### LUBRICATION

The Pump is supplied with the correct amount of lubrication oil (see table on page 25). Periodically check the oil level in the Pump through the oil level indicator.

**Use OIL type SAE 15W-40** or equivalent. Here are some recommended types of oil:

BRAND	TYPE
AGIP	F.1 Supermotoroil 20W-40
BP	Vanellus C 20W-40
CASTROL	GTX 20W-40
ESSO	Uniflo 20W-40
MOBIL	Super M 20W-40
SHELL	Rimula R4 20W-40 / Helix Super 20W40
TOTAL	Rubia 20W-40 / Quartz 5000 20W-40

The oil is to be changed by draining it through the dedicated bottom oil drain plug and strictly with the Pump stopped.

Every time you unscrew the oil drain plug we suggest replacing its gasket



**DO NOT START THE PUMP IF THERE IS NO OIL IN THE PUMP!**



During maintenance, you are recommended to:

- Use and wear suitable personal protection equipment (i.e. gloves). Wait for the machine to cool down and to have stopped completely.



During maintenance, do not throw residues outdoors but observe current standards.



If the Pump is to be scrapped:

1. Separate the various parts depending on their type (i.e. plastic, harmful fluids, metal etc.).
2. Use public or private waste disposal systems envisaged by local law to dispose of waste.
3. This device could contain harmful substances: improper use or incorrect disposal could have negative effects on human health and on the environment.

## 9. TROUBLE SHOOTING

PROBLEMS	PROBABLE CAUSES	SOLUTIONS
The Pump doesn't reach required pressure.	Incorrect or worn or plugged nozzle.	Change to proper size nozzle; replace nozzle or clean nozzle.
	Belt slippage.	Tighten or replace belt.
	Air leak in inlet plumbing.	Check or replace hoses or fittings.
	Inlet suction strainer clogged or improper size.	Check and clean, use adequate size.
	Worn seals. Abrasives in Pumped fluid; severe cavitations; inadequate water supply.	Install and maintain proper filter. Replace seals. Check inlet supply: Max. -0,2 bar (-6 inch.Hg) vacuum.
	Pressure gauge is broken or not registering accurately.	Check with new gauge; replace worn or damaged gauge.
	Relief / unloader valve stuck, partially plugged or improperly adjusted.	Adjust or repair or replace relief / unloader valve.
	Dirty or worn inlet or outlet valves.	Check and clean or replace valves.
	Leaky outlet hose.	Check or replace discharge hoses or fittings.
Pump is noisy.	Air leak in inlet plumbing.	Check or replace hoses or fittings.
	Inlet strainer clogged or improper size or insufficient supply of water to the Pump.	Check and clean, use adequate size; increase water supply if not sufficient.
	Dirty or worn inlet or outlet valves.	Check and clean or replace valves.
	Worn seals or o-rings.	Replace seals or o-rings.
	Plugged inlet filter or improper size.	Clean or replace filter.
	Pulley loose on crankshaft or worn key.	Check pulleys and key.
	Broken or worn bearings.	Replace bearings.
Water leakage under the Pump head.	Worn low pressure seal or o-ring.	Replace seal or o-ring.
	Cracked plunger.	Install new plunger.
Water in crankcase. Oil is changing color into white.	High humidity in air (condensing).	Change oil every 250 hours instead of 500.
	Worn crankcase oil seal.	Replace crankcase oil seal.
	Worn low pressure seal.	Replace seal.
Oil leak between crankcase and head.	Worn crankcase oil seal.	Check plunger rod. Replace crankcase oil seal.
Oil leak in the area of crankshaft.	Worn crankshaft oil seal.	Replace crankshaft oil seal.
	Worn bearing case o-ring.	Replace bearing case o-ring.
	Bad bearings.	Replace bearings.
Oil leak at the reared of the Pump.	Damaged or improperly installed sight glass or crankcase cover seal or drain plug.	Replace sight glass, plug or seals.
Frequent or premature failure of the packing.	Scored plungers.	Replace plungers.
	Over pressure in inlet manifold.	Reduce inlet pressure.
	Abrasive material in the fluid being Pumped.	Install proper filter on Pump inlet plumbing.
	Corrosive additives in the fluid being Pumped.	Use clean water or contact SKY Technical Service Department for more information's.
	Excessive temperature of fluid being Pumped.	Assure fluid inlet temperature are within specified range (see page 20).
	Running Pump dry.	Do not run Pump without fluid.
Excessive vibrations in outlet line.	Air leak in inlet plumbing.	Check or replace hoses or fittings.
	Pulsation damper pressure too low.	Check and repressure.
	Dirty or worn inlet or outlet valves.	Check and clean or replace valves.

# MMD

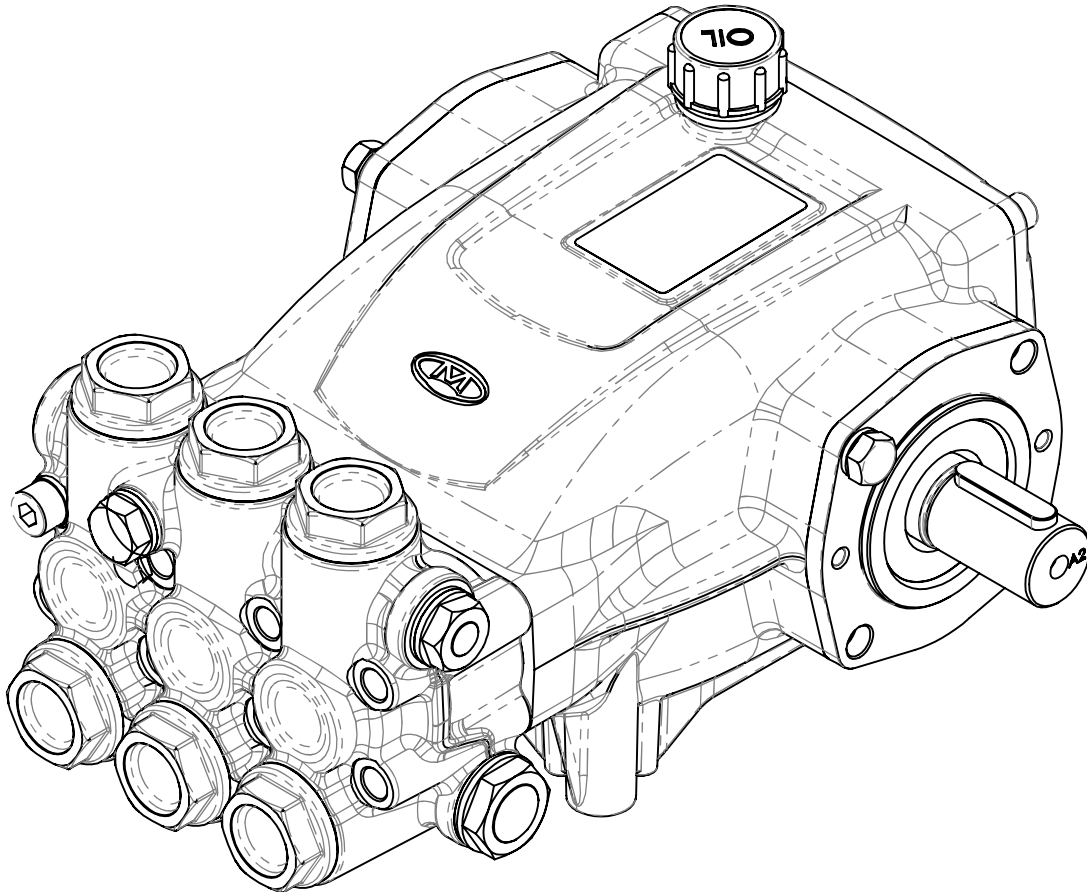

General table

Model	Pressure (Bar)	Pressure (Psi)	Flow Rate 1450 rpm (Lit/min)	Flow Rate 1740 rpm (Lit/min)	Flow Rate 1450 rpm (gpm)	Flow Rate 1740 rpm (gpm)	Round 50Hz (RPM)	Round 60Hz (RPM)	Power 50Hz (Hp)	Power 50Hz (Kw)	Power 60Hz (Hp)	Power 60Hz (Kw)
<b>MMD12250 (R-L)</b>	250	3625	12.00	14.40	3.17	3.80	1450	1740	7.79	5.82	9.35	6.98
<b>MMD15250 (R-L)</b>	250	3625	15.00	18.00	3.96	4.75	1450	1740	9.74	7.27	11.69	8.72
<b>MMD18250 (R-L)</b>	250	3625	18.00	21.60	4.75	5.70	1450	1740	1.69	8.72	14.03	10.47
<b>MMD21250 (R-L)</b>	250	3625	21.00	25.20	5.55	6.65	1450	1740	13.64	10.18	16.36	12.21

Model	Pressure (Bar)	Pressure (Psi)	Flow Rate 1000 rpm (Lit/min)	Flow Rate 1200 rpm (Lit/min)	Flow Rate 1000 rpm (gpm)	Flow Rate 1200 rpm (gpm)	Round 50Hz (RPM)	Round 60Hz (RPM)	Power 50Hz (Hp)	Power 50Hz (Kw)	Power 60Hz (Hp)	Power 60Hz (Kw)
<b>MMD15250 (R-L)</b>	250	3625	15.00	18.00	3.96	4.75	1000	1200	9.74	7.27	11.69	8.72



# Exploded MMD

## Espoloso MMD

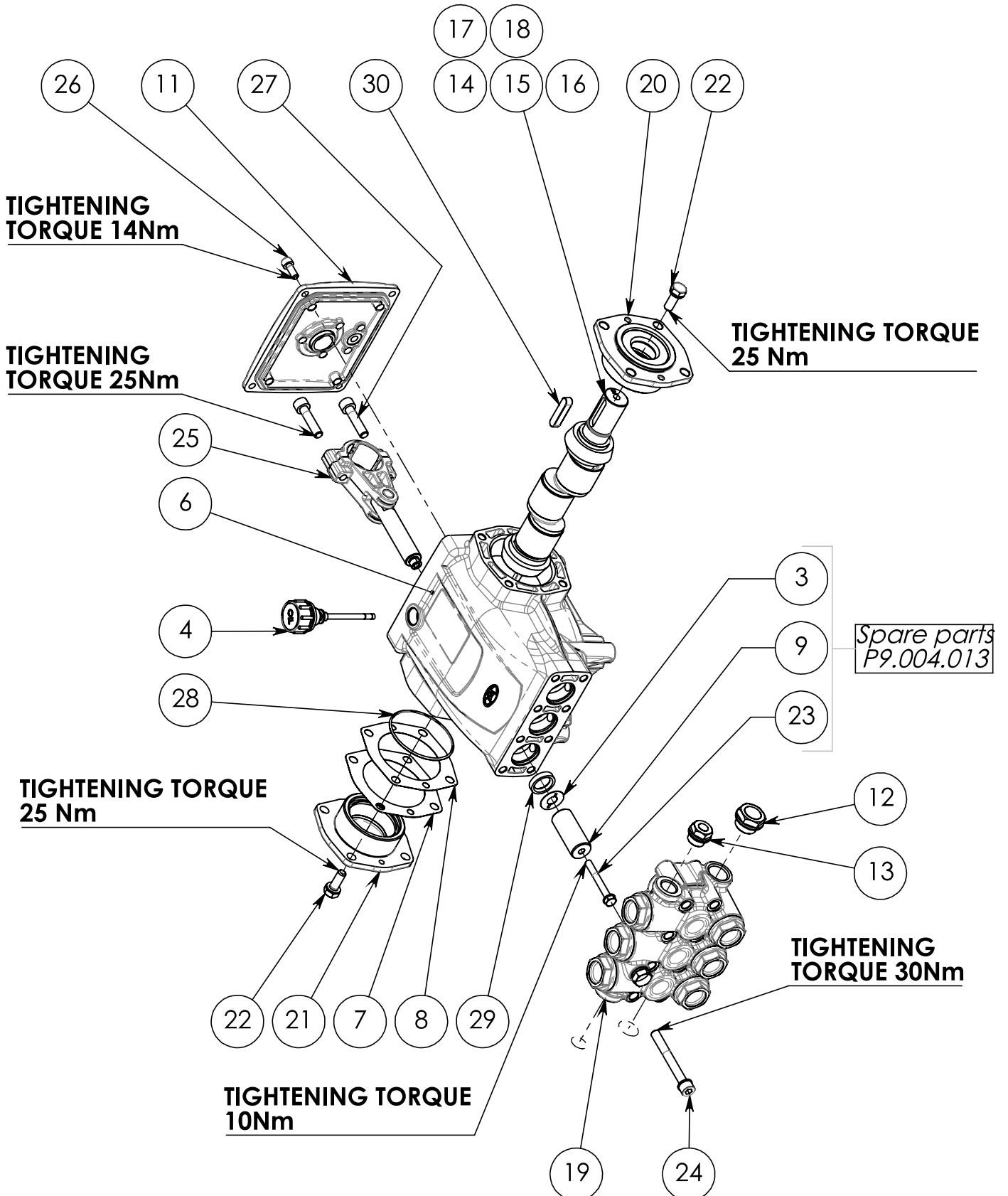



Pos.	MMD 12250 (R-L) Q.TY	MMD 15250 (R-L) Q.TY	MMD 18250 (R-L) Q.TY	MMD 21250 (R-L) Q.TY	MMD 15250 (R-L) 1000rpm Q.TY	Code	ITALIANO	ENGLISH	DEUTSCH	ESPAÑOL	FRANCAIS
2	1	1	1	1	1	P0.020.003	Olio o Lubrificante HYDRAULIC 0.7 LIT	Oil or Lubricants HYDRAULIC 0.7 LIT	Öl oder Schmierstoffe HYDRAULIC 0.7 LIT	Aceite o lubricante HYDRAULIC 0.7 LIT	ÖlHuile ou lubrifiant HYDRAULIC 0.7 LIT
3	3	3	3	3	3	P1.003.003	Rondella Rame ø23.5 ø9.6X0.5	Copper washer ø23.5 ø9.6X0.5	Kupferunterlegsscheibe ø23.5 ø9.6X0.5	Arandela de cobre ø23.5 ø9.6X0.5	Rondelle cuivre ø23.5 ø9.6X0.5
4	1	1	1	1	1	P1.012.006	Tappo G3/8" L.75	Cap G3/8" L.75	Deckel G3/8" L.75	Tapón G3/8" L.75	Bouchon G3/8" L.75
6	1	1	1	1	1	P1.020.006	Corpo Pompa MM-2	Pump Body MM-2	Pumpenkörper MM-2	Cuerpo de la bomba MM- 2	Corps de pompe MM-2
7	1	1	1	1	1	P1.060.007	Distanziale MM-2" Sp.0.19	Spacer MM-2" Sp.0.19	Distanzstueck MM-2" Sp.0.19	Distanciador MM-2" Sp.0.19	Entretoise MM-2" Sp.0.19
8	1	1	1	1	1	P1.060.008	Distanziale "MM-2" Sp.0.05	Spacer "MM-2" Sp.0.05	Distanzstueck "MM-2" Sp.0.05	Distanciador "MM-2" Sp.0.05	Entretoise "MM-2" Sp.0.05
9	3	3	3	3	3	P1.071.013	Pistone ø20 h46-MM-2	Piston ø20 h46-MM-2	Kolben ø20 h46-MM-2	Pistón ø20 h46-MM-2	Piston ø20 h46-MM-2
11	1	1	1	1	1	P2.012.001	Coperchio MMD	Cover MMD	Deckel MMD	Tapa MMD	Couvercle MMD
12	1	1	1	1	1	P2.013.021	Tappo 1/2" GAS	Cap 1/2" GAS	Deckel 1/2" GAS	Tapón 1/2" GAS	Bouchon 1/2" GAS
13	1	1	1	1	1	P2.013.022	Tappo 3/8" GAS	Cap 3/8" GAS	Deckel 3/8" GAS	Tapón 3/8" GAS	Bouchon 3/8" GAS
14	-	-	-	1	-	P2.014.011	Albero -E-MM-2	Shaft -E-MM-2	Welle -E-MM-2	Eje -E-MM-2	Arbre -E-MM-2
15	-	1	-	-	-	P2.014.012	Albero -A-MM-2	Shaft -A-MM-2	Welle -A-MM-2	Eje -A-MM-2	Arbre -A-MM-2
16	1	-	-	-	-	P2.014.013	Albero -B-MM-2	Shaft -B-MM-2	Welle -B-MM-2	Eje -B-MM-2	Arbre -B-MM-2
17	-	-	1	-	-	P2.014.014	Albero -C-MM-2	Shaft -C-MM-2	Welle -C-MM-2	Eje -C-MM-2	Arbre -C-MM-2
18	-	-	-	-	1	P2.014.015	Albero -D-MM-2	Shaft -D-MM-2	Welle -D-MM-2	Eje -D-MM-2	Arbre -D-MM-2
19	1	1	1	1	1	P2.035.011	Testata pompa MMD	Pump head MMD	Pumpekopf MMD	Cabeza bomba MMD	Tete de pompe MMD
20	1	1	1	1	1	P2.060.005	Flangia PDF MM-2	Flange PDF MM-2	Flansch PDF MM-2	Borde PDF MM-2	Bride PDF MM-2
21	1	1	1	1	1	P2.060.006	Flangia MMD	Flange MMD	Flansch MMD	Borde MMD	Bride MMD
22	8	8	8	8	8	P2.119.002	Vite M8X22	Screw M8X22	Schrauben M8X22	Tornillo M8X22	Vis M8X22
23	3	3	3	3	3	P2.119.003	Vite M6X50	Screw M6X50	Schrauben M6X50	Tornillo M6X50	Vis M6X50
24	8	8	8	8	8	P2.119.007	Vite M8X70	Screw M8X70	Schrauben M8X70	Tornillo M8X70	Vis M8X70
25	3	3	3	3	3	P2.150.006	Biella MMD	Connecting rod MMD	Plenelstange MMD	Biela MMD	Bielle MMD
26	4	4	4	4	4	P4.002.004	Vite M6x16 UNI5931	Screw M6x16 UNI5931	Schrauben M6x16 UNI5931	Tornillo M6x16 UNI5931	Vis M6x16 UNI5931
27	6	6	6	6	6	P4.002.016	Vite M8x35 UNI5931-67	Screw M8x35 UNI5931-67	Schrauben M8x35 UNI5931-67	Tornillo M8x35 UNI5931- 67	Vis M8x35 UNI5931-67
28	1	1	1	1	1	P4.005.025	Guarnizione ORM 61.0X2.0	Gasket ORM 61.0X2.0	Dichtung ORM 61.0X2.0	Guarnición ORM 61.0X2.0	Garniture ORM 61.0X2.0
29	1	1	1	1	1	P4.015.002	Anello 16x24x5 NBR	Ring 16x24x5 NBR	Ring 16x24x5 NBR	Anillo 16x24x5 NBR	Bague 16x24x5 NBR
30	1	1	1	1	1	P4.021.001	Chiavetta 8x7x35	Key 8x7x35	Keil 8x7x35	Chaveta 8x7x35	Clavette 8x7x35

# MMD Drawing

## Disegno MMD

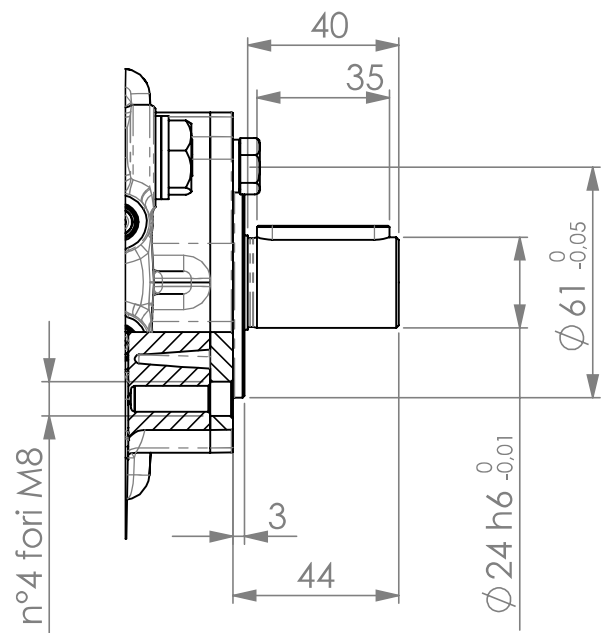
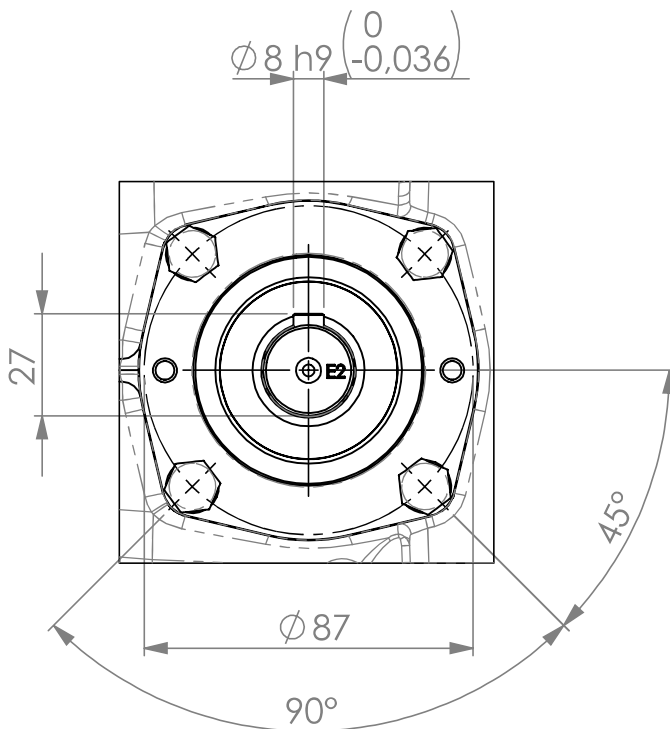
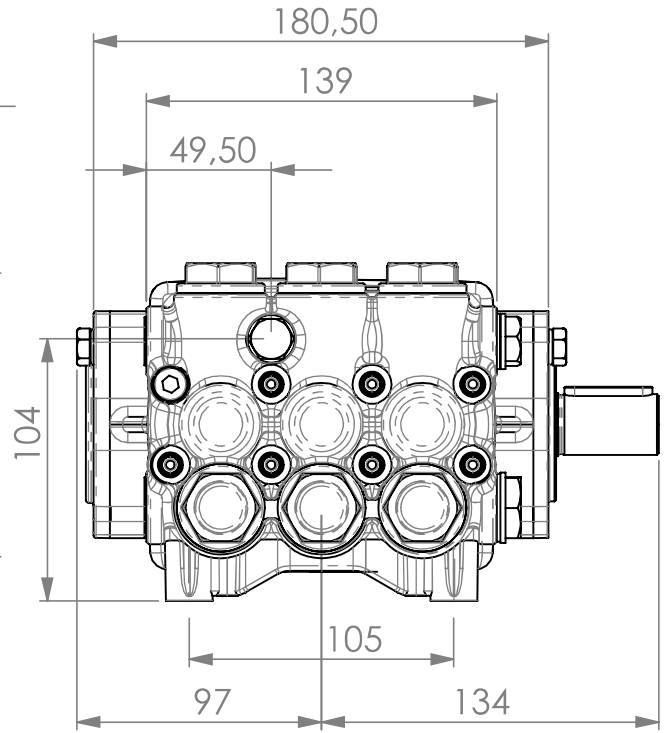
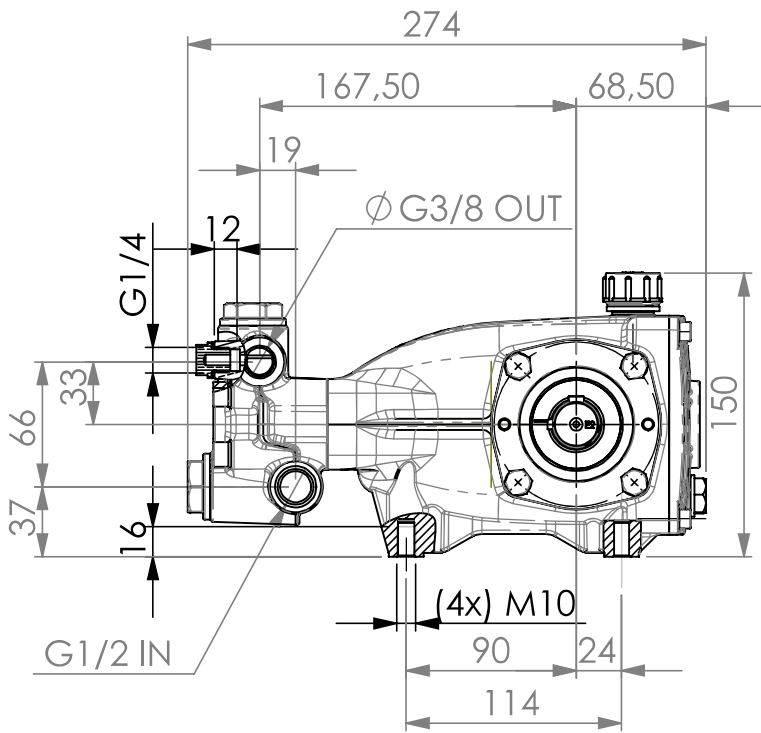

# Pump head MMD

## Testata pompa MMD



Use LOCTITE 270.  
**TIGHTENING TORQUE 40Nm**

Spare parts  
P9.003.025

Spare parts  
P9.001.005

**TIGHTENING TORQUE 25Nm**

Spare parts  
P9.003.026

Use LOCTITE 270.  
**TIGHTENING TORQUE 40Nm**

Spare parts  
P9.001.005

**P2.035.011.C**

Spare parts P9.040.017

Pos.	Q.Ty	Code	ITALIANO	ENGLISH	DEUTSCH	ESPAÑOL	FRANCAIS
1	1	P1.043.014	Testata pompa MM-2	Pump head MM-2	Pumpekopf MM-2	Cabeza bomba MM-2	Tete de pompe MM-2
2	6	P2.013.007	Tappo V.A.M. +OR	Cap V.A.M. +OR	Deckel V.A.M. +OR	Tapón V.A.M. +OR	Bouchon V.A.M. +OR
3	6	P2.003.006	Valvola VAM 21L/min ø21 MM-1	Valve VAM 21L/min ø21 MM-1	Ventil VAM 21L/min ø21 MM-1	Válvula VAM 21L/min ø21 MM-1	Valve VAM 21L/min ø21 MM-1
4	6	P4.005.001	OR 3068 NBR	O-ring 3068 NBR	O-Ring 3068 NBR	OR 3068 NBR	Joint torique 3068 NBR
5	1	P4.008.007	Rondella Rame 1/4 Ø13x19x1.5	Copper washer 1/4 Ø13x19x1.5	Kupferunterlegsscheibe 1/4 Ø13x19x1.5	Arandela de cobre 1/4 Ø13x19x1.5	Rondelle cuivre 1/4 Ø13x19x1.5
6	1	P1.012.002	Tappo 1/4"Gas	Cap 1/4"Gas	Deckel 1/4"Gas	Tapón 1/4"Gas	Bouchon 1/4"Gas
6.1	1	P4.100.002	Tenuta pistone anteriore ø20xø28x8	Front piston seal ø20xø28x8	Front Kolbendichtung ø20xø28x8	Junta del pistón delantero ø20xø28x8	Joint de piston avant ø20xø28x8
6.2	1	P4.005.029	Guarnizione OR 2118 NBR-1.78x29.87	Gasket OR 2118 NBR-1.78x29.87	Dichtung OR 2118 NBR-1.78x29.87	Guarnición OR 2118 NBR-1.78x29.87	Garniture OR 2118 NBR-1.78x29.87
7	3	P1.024.017	Diffusore MM-2	Diffusor MM-2	Diffusor MM-2	Difusor MM-2	Diffuseur MM-2
8	3	P4.100.001	Tenuta pistone anteriore ø20xø30x9	Front piston seal ø20xø30x9	Front Kolbendichtung ø20xø30x9	Junta del pistón delantero ø20xø30x9	Joint de piston avant ø20xø30x9
9	3	P2.118.003	Pressore MM-2	Pressure Ring MM-2	Bague de pression MM-2	Anillo de presión MM-2	Bague de pression MM-2

# Connecting rod MMD

## Biella MMD

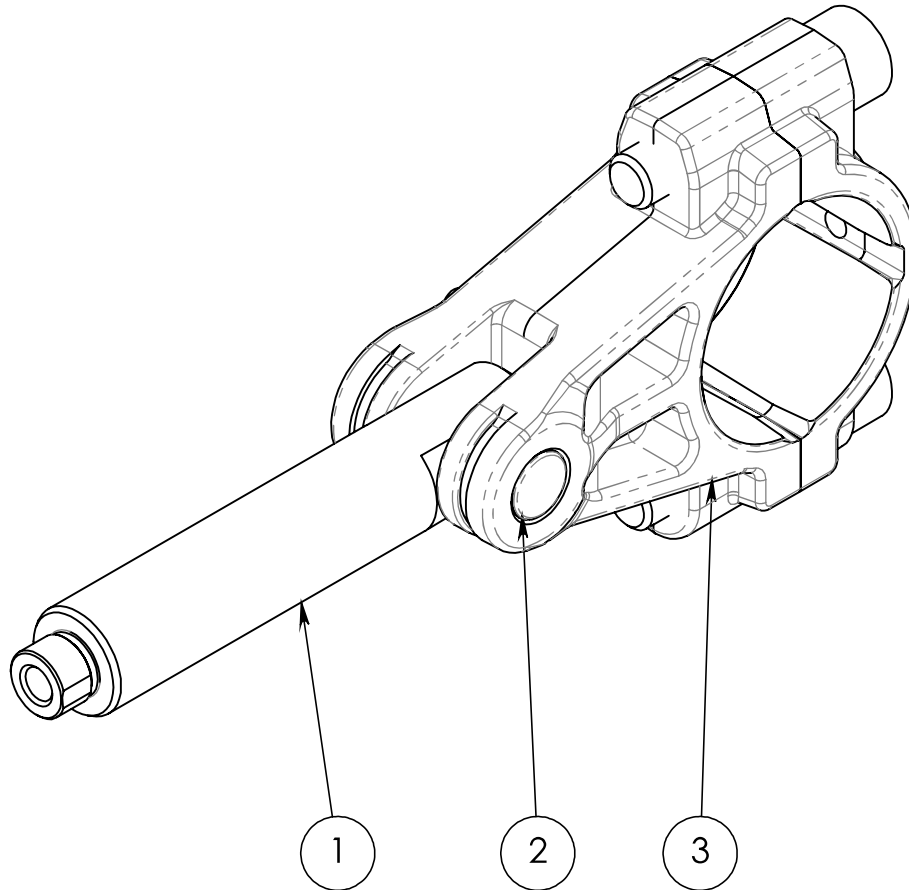

**P2.150.006.A**

*Spare parts P9.041.004*

Pos.	Q.ty	Code	ITALIANO	ENGLISH	DEUTSCH	ESPAÑOL	FRANCAIS
1	1	P1.010.008	Asta MMD	Pole MMD	Pfosten MMD	Asta MMD	Tige MMD
2	1	P1.013.004	Spina cilindrica ø10x30	Cylindrical pin ø10x30	Zylinder Stiff ø10x30	Pasador cilindrico ø10x30	Goupille cylindrique ø10x30
3	1	P1.099.006	Biella MMD	Connecting rod MMD	Plenelstange MMD	Biela MMD	Bielle MMD

# Cover MMD

## Coperchio MMD

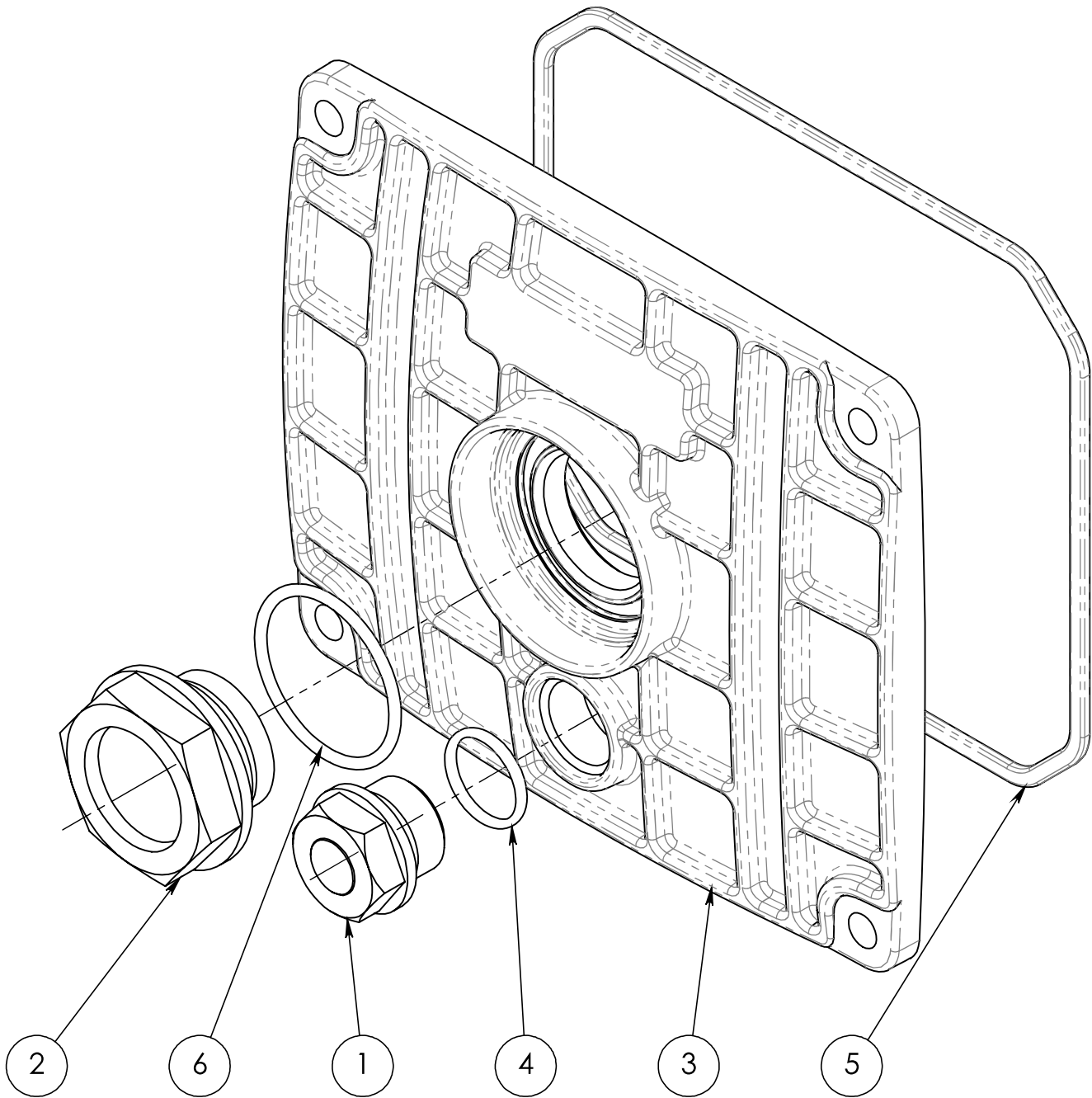

**P2.012.001.F**

Pos.	Q.ty	Code	ITALIANO	ENGLISH	DEUTSCH	ESPAÑOL	FRANCAIS
1	1	P1.012.003	Tappo G 3/8" H18	Cap G 3/8" H18	Deckel G 3/8" H18	Tapón G 3/8" H18	Bouchon G 3/8" H18
2	1	P1.012.015	Tappo G3/4	Cap G3/4	Deckel G3/4	Tapón G3/4	Bouchon G3/4
3	1	P1.054.001	Coperchio "MM"	Cover "MM"	Deckel "MM"	Tapa "MM"	Couvercle "MM"
4	1	P4.005.007	Guarnizione OR 2056 14x1.78NBR 70Sh	Gasket OR 2056 14x1.78NBR 70Sh	Dichtung OR 2056 14x1.78NBR 70Sh	Guarnición OR 2056 14x1.78NBR 70Sh	Garniture OR 2056 14x1.78NBR 70Sh
5	1	P4.005.026	Guarnizione ORM 126X3.0	Gasket ORM 126X3.0	Dichtung ORM 126X3.0	Guarnición ORM 126X3.0	Garniture ORM 126X3.0
6	1	P4.005.030	OR ORM0285-20 (NBR)	O-ring ORM0285-20 (NBR)	O-Ring ORM0285-20 (NBR)	OR ORM0285-20 (NBR)	Joint torique ORM0285-20 (NBR)

# Spare Parts Ricambi



Code	Q.ty	ITALIANO	ENGLISH	DEUTSCH	ESPAÑOL	FRANCAIS
P2.003.006	6	Valvola VAM 21L/min ø21 MM-1	Valve VAM 21L/min ø21 MM-1	Ventil VAM 21L/min ø21 MM-1	Válvula VAM 21L/min ø21 MM-1	Valve VAM 21L/min ø21 MM-1
P4.005.001	6	OR 3068 NBR	O-ring 3068 NBR	O-Ring 3068 NBR	OR 3068 NBR	Joint torique 3068 NBR
P4.005.002	6	OR 2.62x20.29	O-ring 2.62x20.29	O-Ring 2.62x20.29	OR 2.62x20.29	Joint torique 2.62x20.29

P9.001.005  
KIT VALVOLA COMPLETA POMPA MM-2 - KIT VALVES FOR MM PUMP



Code	Q.ty	ITALIANO	ENGLISH	DEUTSCH	ESPAÑOL	FRANCAIS
P4.005.029	3	Guarnizione OR 2118 NBR-1.78x29.87	Gasket OR 2118 NBR-1.78x29.87	Dichtung OR 2118 NBR-1.78x29.87	Guarnición OR 2118 NBR-1.78x29.87	Garniture OR 2118 NBR-1.78x29.87
P4.100.001	3	Tenuta pistone anteriore ø20xø30x9	Front piston seal ø20xø30x9	Front Kolbendichtung ø20xø30x9	Junta del pistón delantero ø20xø30x9	Joint de piston avant ø20xø30x9
P4.100.002	3	Tenuta pistone posteriore ø20xø28x8	Piston seal back ø20xø28x8	Kolbendichtung zurück ø20xø28x8	Piston sellado posterior ø20xø28x8	Piston joint arrière ø20xø28x8

P9.003.025  
GUARNIZIONE PISTONE ø20 POMPA MM-2 - KIT PLUNGER SEALS ø20 FOR MM PUMP



Code	Q.ty	ITALIANO	ENGLISH	DEUTSCH	ESPAÑOL	FRANCAIS
P1.024.017	1	Diffusore MM-2	Diffusor MM-2	Diffusor MM-2	Difusor MM-2	Diffuseur MM-2
P1.070.019	1	Pressore MM-2	Pressure Ring MM-2	Bague de pression MM-2	Anillo de presión MM-2	Bague de pression MM-2
P4.005.029	1	Guarnizione OR 2118 NBR-1.78x29.87	Gasket OR 2118 NBR-1.78x29.87	Dichtung OR 2118 NBR-1.78x29.87	Guarnición OR 2118 NBR-1.78x29.87	Garniture OR 2118 NBR-1.78x29.87
P4.100.001	1	Tenuta pistone anteriore ø20xø30x9	Front piston seal ø20xø30x9	Front Kolbendichtung ø20xø30x9	Junta del pistón delantero ø20xø30x9	Joint de piston avant ø20xø30x9
P4.100.002	1	Tenuta pistone posteriore ø20xø28x8	Piston seal back ø20xø28x8	Kolbendichtung zurück ø20xø28x8	Piston sellado posterior ø20xø28x8	Piston joint arrière ø20xø28x8

P9.003.026  
GUARNIZIONE PISTONE ø20 POMPA MM-2 PACCO COMPLETO - KIT COMPLETE SEALS



Code	Q.ty	ITALIANO	ENGLISH	DEUTSCH	ESPAÑOL	FRANCAIS
P1.003.003	1	Rondella Rame ø23.5 ø9.6X0.5	Copper washer ø23.5 ø9.6X0.5	Kupferunterlegsscheibe ø23.5 ø9.6X0.5	Arandela de cobre ø23.5 ø9.6X0.5	Rondelle cuivre ø23.5 ø9.6X0.5
P1.071.013	1	Pistone ø20 h46-MM-2	Piston ø20 h46-MM-2	Kolben ø20 h46-MM-2	Pistón ø20 h46-MM-2	Piston ø20 h46-MM-2
P4.002.015	1	Vite M6x50 stainless steel	Screw M6x50 stainless steel	Schrauben M6x50 stainless steel	Tornillo M6x50 stainless steel	Vis M6x50 stainless steel
P4.008.003	1	Rondella Rame ø6,4x12,5x1,6	Copper washer ø6,4x12,5x1,6	Kupferunterlegsscheibe ø6,4x12,5x1,6	Arandela de cobre ø6,4x12,5x1,6	Rondelle cuivre ø6,4x12,5x1,6

P9.004.013  
KIT PISTONE ø20 POMPA MM-2 - KIT CERAMIC PISTON



Code	Q.ty	ITALIANO	ENGLISH	DEUTSCH	ESPAÑOL	FRANCAIS
P4.015.002	3	Anello 16x24x5 NBR	Ring 16x24x5 NBR	Ring 16x24x5 NBR	Anillo 16x24x5 NBR	Bague 16x24x5 NBR

P9.039.001  
ANELLI TENUTA OLIO ASTA POMPA MM-PM - KIT OIL SEALS

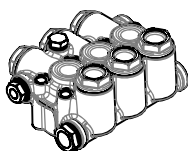

Code	Q.ty	ITALIANO	ENGLISH	DEUTSCH	ESPAÑOL	FRANCAIS
P2.013.022	1	Tappo 3/8" GAS	Cap 3/8" GAS	Deckel 3/8" GAS	Tapón 3/8" GAS	Bouchon 3/8" GAS
P2.013.021	1	Tappo 1/2" GAS	Cap 1/2" GAS	Deckel 1/2" GAS	Tapón 1/2" GAS	Bouchon 1/2" GAS
P2.035.011	1	Testata pompa MMD	Pump head MMD	Pumpekopf MMD	Cabeza bomba MMD	Tete de pompe MMD
P4.043.001	1	Protezione ø20	Protection ø20	Schutz ø20	Protección ø20	Protection ø20
P4.043.002	1	Protezione 15.5	Protection 15.5	Schutz 15.5	Protección 15.5	Protection 15.5

P9.040.017  
KIT TESTATA COMPLETA PISTONE ø20 POMPA MMD - COMPLETE HEAD OF THE PUMP



Code	Q.ty	ITALIANO	ENGLISH	DEUTSCH	ESPAÑOL	FRANCAIS
P2.150.006	1	Biella MMD	Connecting rod MMD	Plenelstange MMD	Biela MMD	Bielle MMD
P4.002.016	2	Vite M8x35 UNI5931-67	Screw M8x35 UNI5931-67	Schrauben M8x35 UNI5931-67	Tornillo M8x35 UNI5931-67	Vis M8x35 UNI5931-67

P9.041.004  
BIELLA -ASTA POMPA MMD - PREASSEMBLED CONNECTING ROD

<p><b>MASSIMA TEMPERATURA INGRESSO ACQUA</b> MAX INPUT WATER TEMPERATURE</p> <p><b>65°C</b> <b>149° F</b></p>	<p><b>PRESSIONE MINIMA INGRESSO</b> MINIMAL INPUT PRESSURE</p> <p><b>0.2 BAR</b> <b>2.9 PSI</b></p>	<p><b>INGRESSO</b> INLET</p> <p><b>G 1/2"</b></p>	<p><b>USCITA</b> OUTLET</p> <p><b>G 3/8"</b></p>
---	---	---	--



Codice Code	Modello Model	Portata / Flow Rate lt/min - gpm		Pressione / Pressure		Potenza / Power		Potenza / Power		Albero Shaft L: 40mm Ø 24
		1450 rpm	1740 rpm	Bar	Psi	50Hz		60Hz		
						HP	Kw	HP	Kw	
P3.020.003-2	<b>MMD12250R</b>	12.00 3.17	14.40 3.80	250.00	3625	7.79	5.82	9.35	6.98	Destra / Right
P3.020.002-2	<b>MMD15250R</b>	15.00 3.96	18.00 4.75	250.00	3625	9.74	7.27	11.69	8.72	Destra / Right
P3.020.004-2	<b>MMD18250R</b>	18.00 4.75	21.60 5.70	250.00	3625	11.69	8.72	14.03	10.47	Destra / Right
P3.020.001-2	<b>MMD21250R</b>	21.00 5.55	25.20 6.65	250.00	3625	13.64	10.18	16.36	12.21	Destra / Right
P3.020.008-2	<b>MMD12250L</b>	12.00 3.17	14.40 3.80	250.00	3625	7.79	5.82	9.35	6.98	Sinistra / Left
P3.020.006-2	<b>MMD15250L</b>	15.00 3.96	18.00 4.75	250.00	3625	9.74	7.27	11.69	8.72	Sinistra / Left
P3.020.009-2	<b>MMD18250L</b>	18.00 4.75	21.60 5.70	250.00	3625	11.69	8.72	14.03	10.47	Sinistra / Left
P3.020.007-2	<b>MMD21250L</b>	21.00 5.55	25.20 6.65	250.00	3625	13.64	10.18	16.36	12.21	Sinistra / Left
		1000 rpm	1200 rpm	Bar	Psi	HP	Kw	HP	Kw	
P3.020.005-2	<b>MMD15250R</b>	15.00 3.96	18.00 4.75	250.00	3625	9.74	7.27	11.69	8.72	Destra / Right
P3.020.010-2	<b>MMD15250L</b>	15.00 3.96	18.00 4.75	250.00	3625	9.74	7.27	11.69	8.72	Sinistra / Left

## RICAMBI / SPARE PARTS

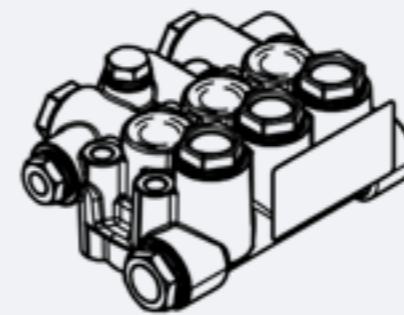

**KIT - P9.040.017**

TESTATA COMPLETA  
COMPLETE HEAD OF THE PUMP



**KIT - P9.039.001**

ANELLI TENUTA OLIO ASTA  
KIT OIL SEAL PUMP MM PM



**KIT - P9.003.025**

GUARNIZIONE PISTONE  
KIT PLUNGER SEALS



**KIT - P9.004.013**

PISTONE DIAMETRO 20  
KIT CERAMIC PISTON - DIAMETER 20



**KIT - P9.001.005**

VALVOLA COMPLETA  
COMPLETE VALVE



**KIT - P9.003.026**

GUARNIZIONE PISTONE - PACCO COMPLETO  
KIT COMPLETE SEALS

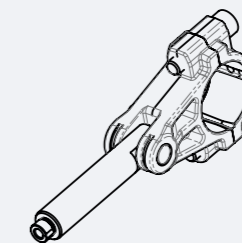

**KIT - P9.041.004**

PREMONTATO BIELLA - ASTA  
PREASSEMBLED CONNECTING ROD

MMD	PORTATA FLOW RATE		GIRI ROUNDS	PRESSIONE MASSIMA MAX PRESSURE		CAPACITÀ OLIO OIL CAPACITY		PESO WEIGHT	
	Lt/min	Gpm	Rpm	Bar	Psi	Lt	Gal	Kg	Lbs
50HZ	12.00 » 21.00	2.24 » 5.54	<b>1450</b>	250	3625	0.7	0.18	10.4	22.92
	15.00	3.96	<b>1000</b>						
60Hz	14.40 » 25.20	2.69 » 4.75	<b>1740</b>						
	18.00	4.75	<b>1200</b>						



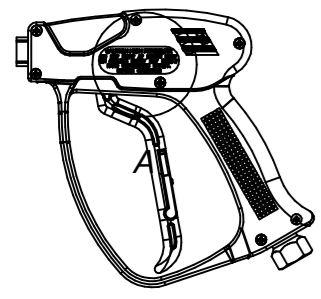

DETTAGLIO A

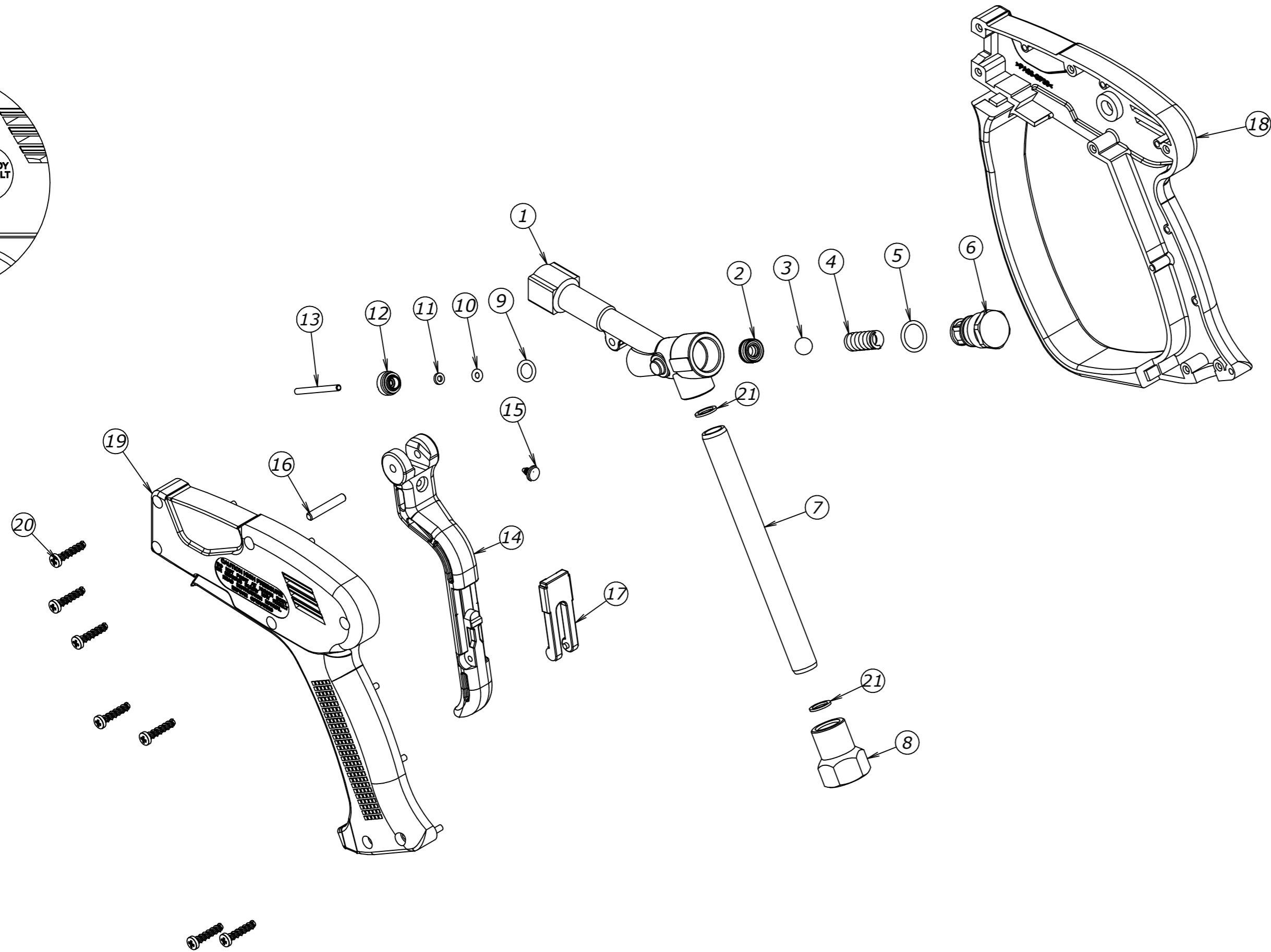
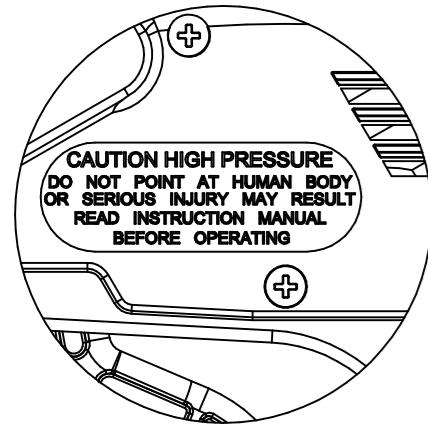

DETTAGLIO B

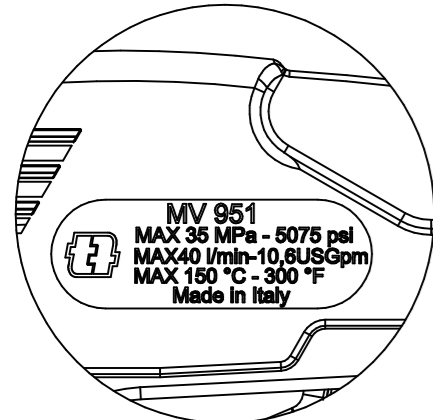

B

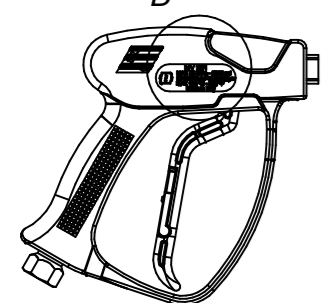

Num.	Codice	Descrizione Completa	Quant.	Kit
1	0109712290	CORPO LAV. NUOVO MV 880 MV 880 82A	1	
2	0106200140	SEDE MV2001 CONIATA CON OR NBR 90	1	X
3	0112720070	SFERA 11/32 AISI440 C GR10 ISO 3290	1	X
4	0107720030	MOLLA 1,6 X 9,4 X 21,5 INOX	1	X
5	0110750053	GUOR 1.78X12.42 2050 NBR 90 NERO	1	X
6	0103710660	TAPPO DIS. MV 2001 33B	1	
7	0113730020	TUBO FE Ø13 L133MM G1/4 ZB	1	
8	0115710010	RACCORDO 3/8 GAS DIS. MV 100 11D	1	
9	0110750930	GUOR 1.78X7.66 2031 NBR 70 NERO	1	X
10	0110750030	GUOR 1.78X2.9 2012 VITON 75 NERO	1	X
11	0117740780	AA. 3,00X5,80X1,20 TB	1	X
12	0129710000	GRANO M 12 X 1	1	X
13	0104720160	STELO DIS. MV 2001 34	1	X
14	0100740510	LEVA MV951 - NERA -	1	
15	0105720010	PASTIGLIA GRILLETTO DIS. MV 100 14B	1	
16	0118730040	SPINA INOX 4 X 25	1	
17	0100740520	SICURA MV951- ROSSA -	1	
18	S02301202	SCOCCA MV951 DX NERA	1	
19	S02301025	SCOCCA MV950 SX NERA	1	
20	0116730010	VITE AUTOF. 4 X 19 UNI 9707	7	
21	0117760000	RONDELLA 8,20X11,40X1,00 AL	2	

Kit ricambio - Repair kit -Cod. 0200103550

DENOMINAZIONE - TITLE MV951 E 3/8G F - U 1/4G F		CODICE CLIENTE - CUSTOMER PART NO.		DISEGN. DWN	Campelli
VIETATO RIPRODURRE O DIVULGARE IN TOTO O IN PARTE IL PRESENTE DISEGNO SENZA AUTORIZZAZIONE SCRITTA DELLA TECOMECC S.p.A.				VISTO APPROVED	RF
IT IS FORBIDDEN TO PARTIALLY OR TOTALLY COPY, USE OR DISCLOSE THIS MATERIAL WITHOUT PRIOR WRITTEN CONSENT FROM TECOMECC S.p.A.				DATA DATE	01/06/10
		42124- REGGIO EMILIA - ITALY		CODICE - PART NO.	4012206004
				REV.	4

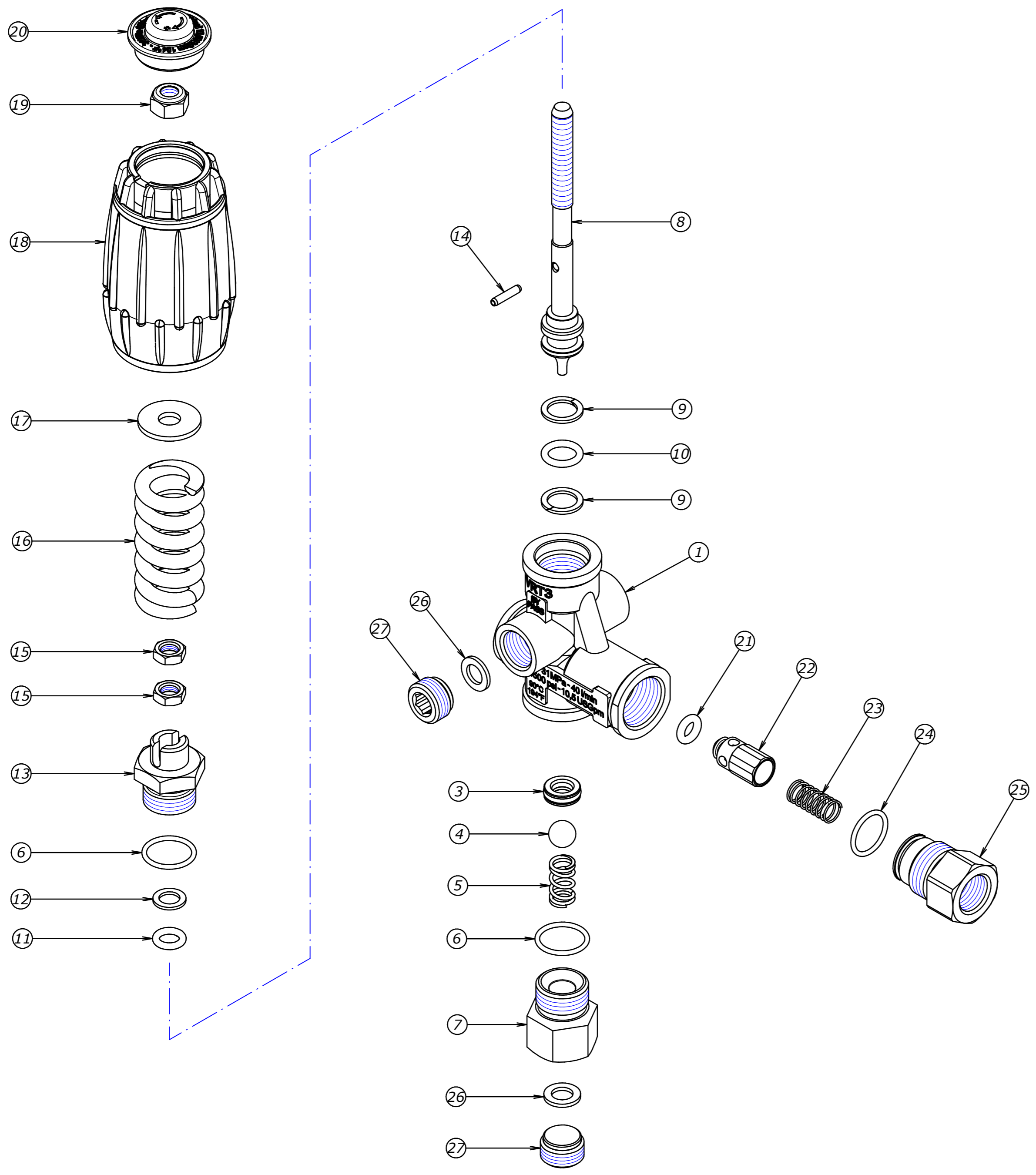

Num.	Codice	Descrizione Completa	Quant.	Kit
1	0109712650	CORPO VRT3 G 3/8 F MV 0316 01B	1	
3	4079500001	SEDE VRT3 Ø8 CONIATA CON OR NBR 90	1	X
4	0112720010	SFERA DIAM.13/32 AISI 440C TEMP G20	1	X
5	0107720820	MOLLA SFERA MV 0316 28	1	
6	0110751311	GUOR 1.78X17.17 2068 NBR 90 NERO	2	X
7	0115712280	RAC.SEDE3/8GF SF13/32' MV 0316 15A	1	
8	0104720230	STELO VRT3 MV 0316 04	1	
9	000125	A.A.11,50x15,9x1,20 TBT 000125B	2	X
10	0110750910	GUOR 2.62X10.78 3043 NBR 70 NERO	1	X
11	0110750170	GUOR 2.62X7.6 3030 NBR 70 NERO	1	X
12	0122790030	A.A.8X12,6X1,2 MV 0316 05	1	X
13	0115712250	RAC.GUIDA STELO VRT3 MV 0316 06	1	
14	0118720120	SPINA ELASTICA UNI ISO 28748 - 3X14	1	
15	030200	DADO VRT-VHP M 8 x 4 OTT.	2	
16	0107770080	MOLLA 5,7X20,7X56 31 MPA MV 0316 19	1	
17	150204	RONDELLA D. 8,5x24,0x2,0 Z.B.	1	
18	400305	MANOPOLA VRT2-VHP ROHS	1	
19	030101	DADO AUTOBLOC.BASSO M8x8 Z.B.	1	
20	0128740090	COPERCHIO MAN.31MPa MV 0316 22	1	
21	060109	GUOR 3.0X6.0 NBR 90 NERO	1	X
22	0157710040	OTTURATORE VRT3 MV 0316 07	1	
23	0107720800	MOLLA OTTURATORE VRT3 MV 0316 08A	1	
24	0110751321	GUOR 1.78X15.6 2062 NBR 90 NERO	1	X
25	0115712260	RACCORDO RITEGNO G3/8 F	1	
26	060200	GUARNIZIONE D.14 x8,3x1,5 RAME	2	
27	170101	TAPPO E.I. G3/8 CILINDRICO OTTONE	2	

KIT RICAMBIO VRT3 - 31 MPa - - - Cod. 4079900005

DENOMINAZIONE - TITLE VRT3 G 3/8 F - 31 MPA + MANOPOLA		CODICE CLIENTE - CUSTOMER PART NO.	
VIETATO RIPRODURRE O DIVULGARE IN TOTO O IN PARTE IL PRESENTE DISEGNO SENZA AUTORIZZAZIONE SCRITTA DELLA TECOMECC S.p.A. IT IS FORBIDDEN TO PARTIALLY OR TOTALLY COPY, USE OR DISCLOSE THIS MATERIAL WITHOUT PRIOR WRITTEN CONSENT FROM TECOMECC S.p.A.			
		CODICE - PART NO.	REV.
		0215010260	3